

Compiling Esterel

Stephen A. Edwards

Department of Computer Science
Columbia University
www.cs.columbia.edu/~sedwards

Outline

Introduction to Esterel and Existing Compilers
My Software Compiler [DAC 2000, TransCAD 2002]
My Hardware Compiler [SLAP 2002, IWLS 2002]

The Esterel Language

Developed by Gérard Berry starting 1983
Originally for robotics applications
Imperative, textual language
Synchronous model of time like that in digital circuits
Concurrent

An Example

```
emit B;
present C then
  emit D end;
```

Force signal present in this cycle (points to present C then)

Make D present if C is (points to emit D end;)

An Example

```
await A;
emit B;
present C then
  emit D end;
pause
```

Wait for next cycle where A is present (points to await A;)

Wait for next cycle (points to pause)

An Example

```
loop
  await A;
  emit B;
  present C then
    emit D end;
  pause
end
```

Infinite Loop (points to loop)

An Example

```
every R do
  loop
    await A;
    emit B;
    present C then
      emit D end;
    pause
  end
end
||
loop
  present B then
    emit C end;
  pause
end
end
```

Run Concurrently (points to ||)

An Example

```
every R do
  loop
    await A;
    emit B;
    present C then
      emit D end;
    pause
  end
end
||
loop
  present B then
    emit C end;
  pause
end
end
```

Restart on R (points to every R do)

An Example

```
every R do
  loop
    await A;
    emit B;
    present C then
      emit D end;
    pause
  end
end
||
loop
  present B then
    emit C end;
  pause
end
end
```

Same-cycle bidirectional communication (points to emit B; and present B then)

An Example

```

every R do
  loop
    await A;
    emit B;
    present C then
      emit D end;
    pause
  end
||
  loop
    present B then
      emit C end;
    pause
  end
end
end

```

Good for hierarchical FSMs

Bad at manipulating data

Hardware Esterel variant
proposed to address this

Automata Compilers

Esterel is a finite-state language, so build an automata:

```

loop
  emit A; await C;
  emit B; pause
end
switch (s) {
  case 0: A = 1; s = 1; break;
  case 1: if (C) B = 1; s = 0; break;
}

```

V1, V2, V3 (INRIA/CMA) [Berry, Gonthier 1992]

Fastest known code; great for programs with few states.

Does not scale; concurrency causes state explosion.

Netlist-based Compilers

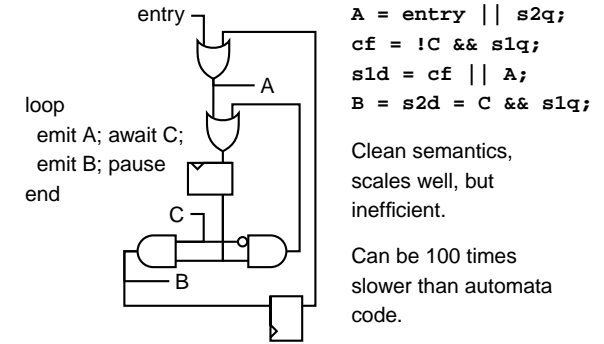

Other Esterel Compilers

Control-flow-graph based

My work: EC [DAC 2000, TransCAD 2002]

Produces very efficient code for acyclic programs only

Discrete-event based

SAXO-RT [Weil et al. 2000]

Produces very efficient code for acyclic programs only

Being improved at Esterel Technologies?

Both proprietary; unlikely to be released.

Neither currently copes with statically cyclic programs.

My Esterel Compiler for Software

Presented at DAC 2000 (also TransCAD 2002)

Used inside Synopsys' CoCentric System Studio to
generate control code

Overview

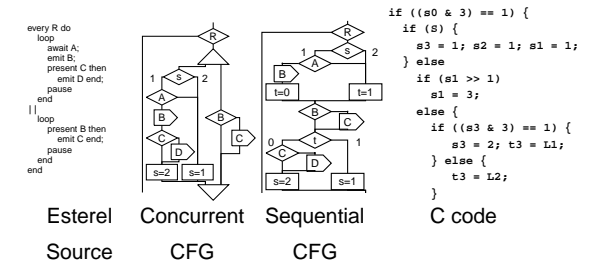

Translate every

```

every R do
  loop
    await A;
    emit B;
    present C then
      emit D end;
    pause
  end
||
  loop
    present B then
      emit C end;
    pause
  end
end
end

```



Add Threads

```

every R do
  loop
    await A;
    emit B;
    present C then
      emit D end;
    pause
  end
||
  loop
    present B then
      emit C end;
    pause
  end
end
end

```

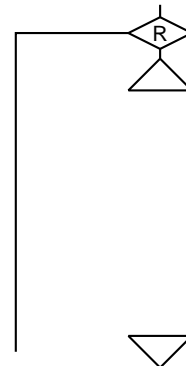

Split at Pauses

```

every R do
  loop
    await A;
    emit B;
    present C then
      emit D end;
    pause
  end
||
  loop
    present B then
      emit C end;
    pause
  end
end
end

```

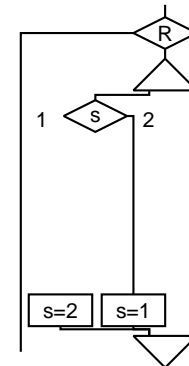

Add Code Between Pauses

```

every R do
  loop
    await A;
    emit B;
    present C then
      emit D end;
    pause
  end
||
  loop
    present B then
      emit C end;
    pause
  end
end
end

```

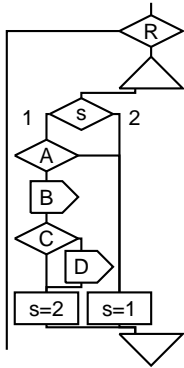

Translate Second Thread

```

every R do
  loop
    await A;
    emit B;
    present C then
      emit D end;
    pause
  end
||
  loop
    present B then
      emit C end;
    pause
  end
end
end

```

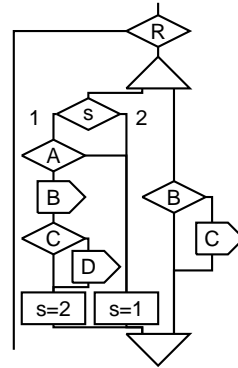

Finished Translating

```

every R do
  loop
    await A;
    emit B;
    present C then
      emit D end;
    pause
  end
||
  loop
    present B then
      emit C end;
    pause
  end
end
end

```

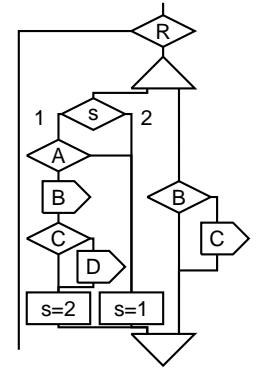

Add Dependencies and Schedule

```

every R do
  loop
    await A;
    emit B;
    present C then
      emit D end;
    pause
  end
||
  loop
    present B then
      emit C end;
    pause
  end
end
end

```

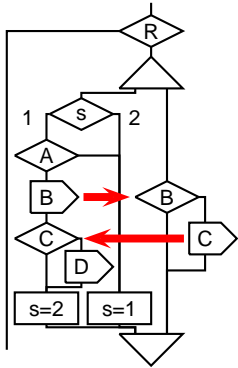

Run First Node

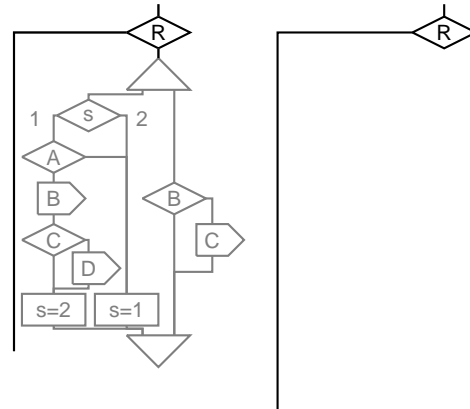

Run First Part of Left Thread

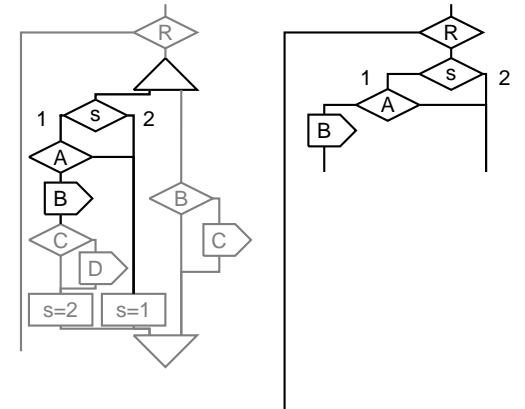

Context Switch

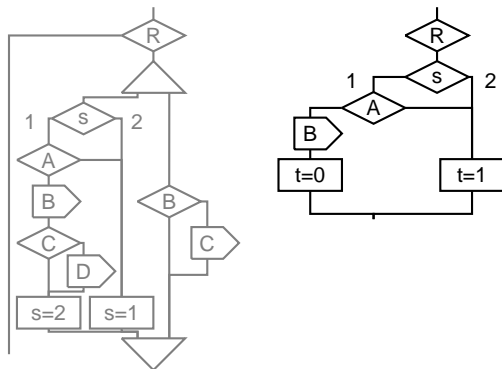

Run Right Thread

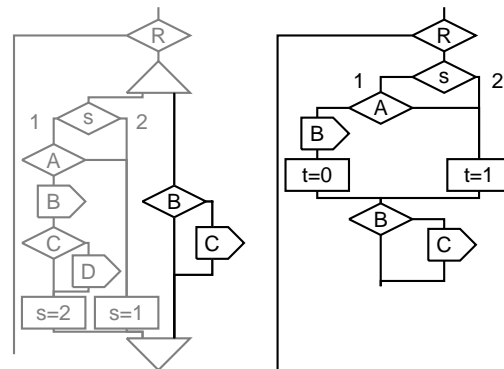

Context Switch

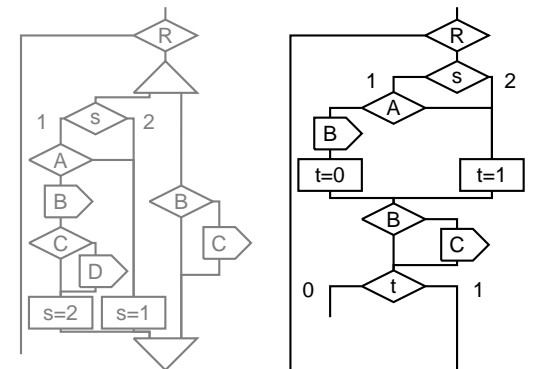

Finish Left Thread

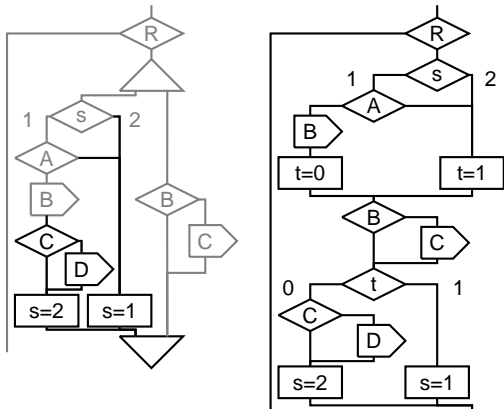

Completed Example

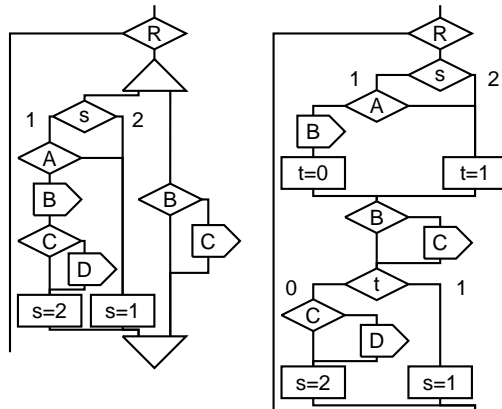

My Esterel Compiler for Hardware

The ESUIF Open Source Esterel Compiler

(Work in Progress)

Presented at SLAP 2002, IWLS 2002

Translation to CCFG

```

every R do
  loop
    await A;
    emit B;
    present C then
      emit D end;
    pause
  end
||
  loop
    present B then
      emit C end;
    pause
  end
end
    
```

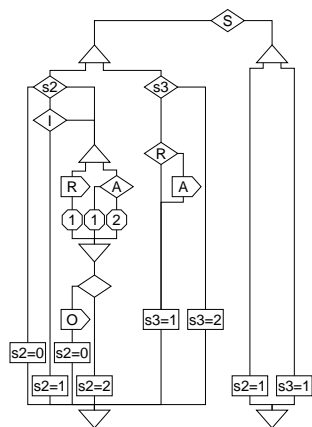

Translation to PDG

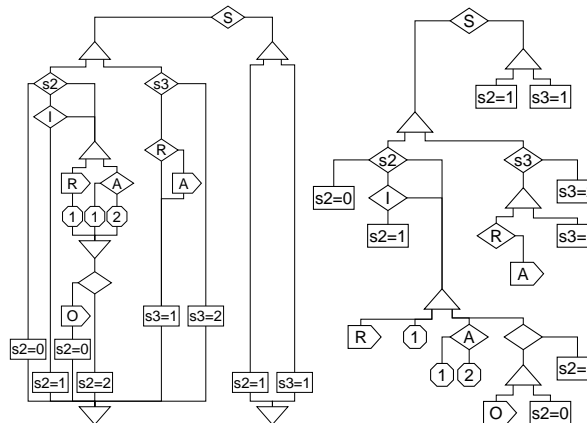

Translation to Circuitry

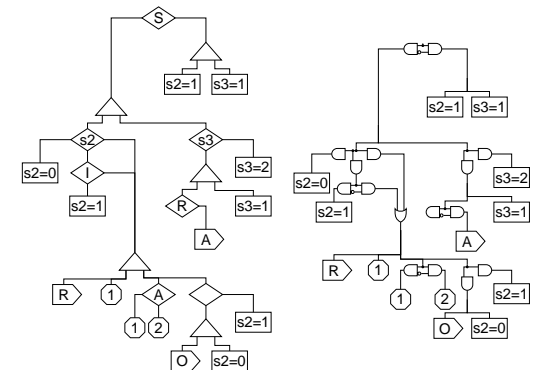

Summary

Introduction to Esterel and Existing Compilers

Synchronous, Concurrent, Textual Language

Automata, Netlist, and Control-based compilers

My Software Compiler [DAC 2000, TransCAD 2002]

Translate to Concurrent CFG, schedule, then
synthesize Sequential CFG

My Hardware Compiler: ESUIF [SLAP 2002, IWLS 2002]

Translate CCFG to Program Dependence Graph

Trivially translate PDG to circuitry

Open-source, under development

Thanks For Your Attention

Stephen A. Edwards

Department of Computer Science

Columbia University

www.cs.columbia.edu/~sedwards

sedwards@cs.columbia.edu