

# CSEE 3827: Fundamentals of Computer Systems

---

Single Cycle MIPS Implementation

# Outline

---

- We will examine two MIPS implementations
  - A single-cycle version
  - A pipelined version
- Simple subset of MIPS, showing most aspects
  - Memory reference: lw, sw
  - Arithmetic/logical: add, sub, and, or, slt
  - Control transfer: beq, j
- *Next unit:* CPU performance factors
  - Instruction count (determined by ISA and compiler)
  - Cycles per instruction and cycle time (determined by CPU hardware)

# Instruction Execution

---

- PC  $\rightarrow$  instruction memory, fetch instruction
- Register numbers  $\rightarrow$  register file, read registers
- Depending on instruction class:
  - Use ALU to calculate:
    - Arithmetic or logical result
    - Memory address for load/store
    - Branch target address
  - Access data for load/store
  - PC  $\leftarrow$  target address or PC + 4

# CPU Overview

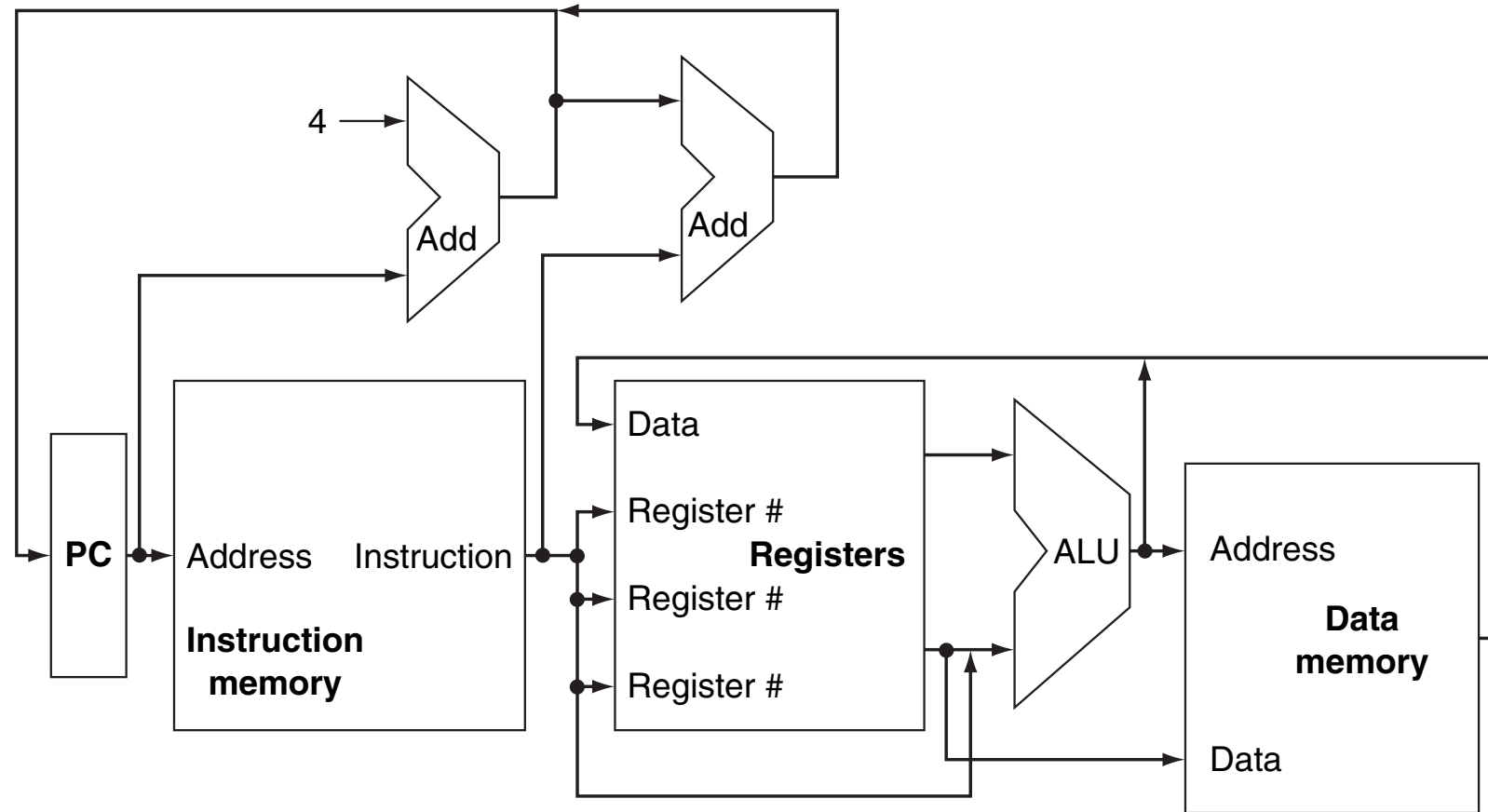

**FIGURE 4.1** An abstract view of the implementation of the MIPS subset showing the major functional units and the major connections between them. All instructions start by using the program counter to supply the instruction address to the instruction memory. After the instruction is fetched, the register operands used by an instruction are specified by fields of that instruction. Once the register operands have been fetched, they can be operated on to compute a memory address (for a load or store), to compute an arithmetic result (for an integer arithmetic-logical instruction), or a compare (for a branch). If the instruction is an arithmetic-logical instruction, the result from the ALU must be written to a register. If the operation is a load or store, the ALU result is used as an address to either store a value from the registers or load a value from memory into the registers. The result from the ALU or memory is written back into the register file. Branches require the use of the ALU output to determine the next instruction address, which comes either from the ALU (where the PC and branch offset are summed) or from an adder that increments the current PC by 4. The thick lines interconnecting the functional units represent buses, which consist of multiple signals. The arrows are used to guide the reader in knowing how information flows. Since signal lines may cross, we explicitly show when crossing lines are connected by the presence of a dot where the lines cross. Copyright © 2009 Elsevier, Inc. All rights reserved.

# Can't just join wires together, use muxes

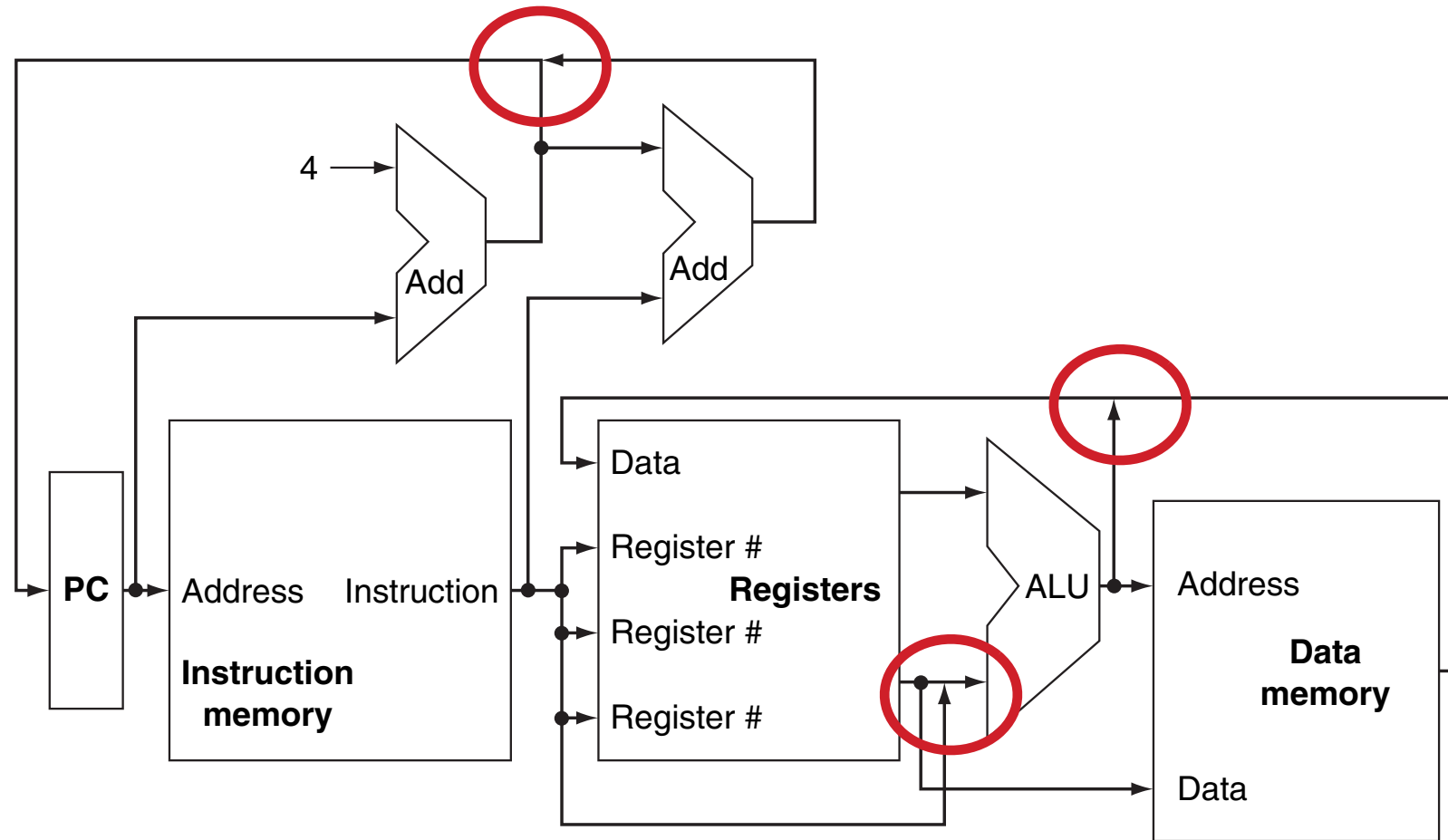

**FIGURE 4.1** An abstract view of the implementation of the MIPS subset showing the major functional units and the major connections between them.

All instructions start by using the program counter to supply the instruction address to the instruction memory. After the instruction is fetched, the register operands used by an instruction are specified by fields of that instruction. Once the register operands have been fetched, they can be operated on to compute a memory address (for a load or store), to compute an arithmetic result (for an integer arithmetic-logical instruction), or a compare (for a branch). If the instruction is an arithmetic-logical instruction, the result from the ALU must be written to a register. If the operation is a load or store, the ALU result is used as an address to either store a value from the registers or load a value from memory into the registers. The result from the ALU or memory is written back into the register file. Branches require the use of the ALU output to determine the next instruction address, which comes either from the ALU (where the PC and branch offset are summed) or from an adder that increments the current PC by 4. The thick lines interconnecting the functional units represent buses, which consist of multiple signals. The arrows are used to guide the reader in knowing how information flows. Since signal lines may cross, we explicitly show when crossing lines are connected by the presence of a dot where the lines cross. Copyright © 2009 Elsevier, Inc. All rights reserved.

# Controller generates selects for the Muxes (and some other stuff)

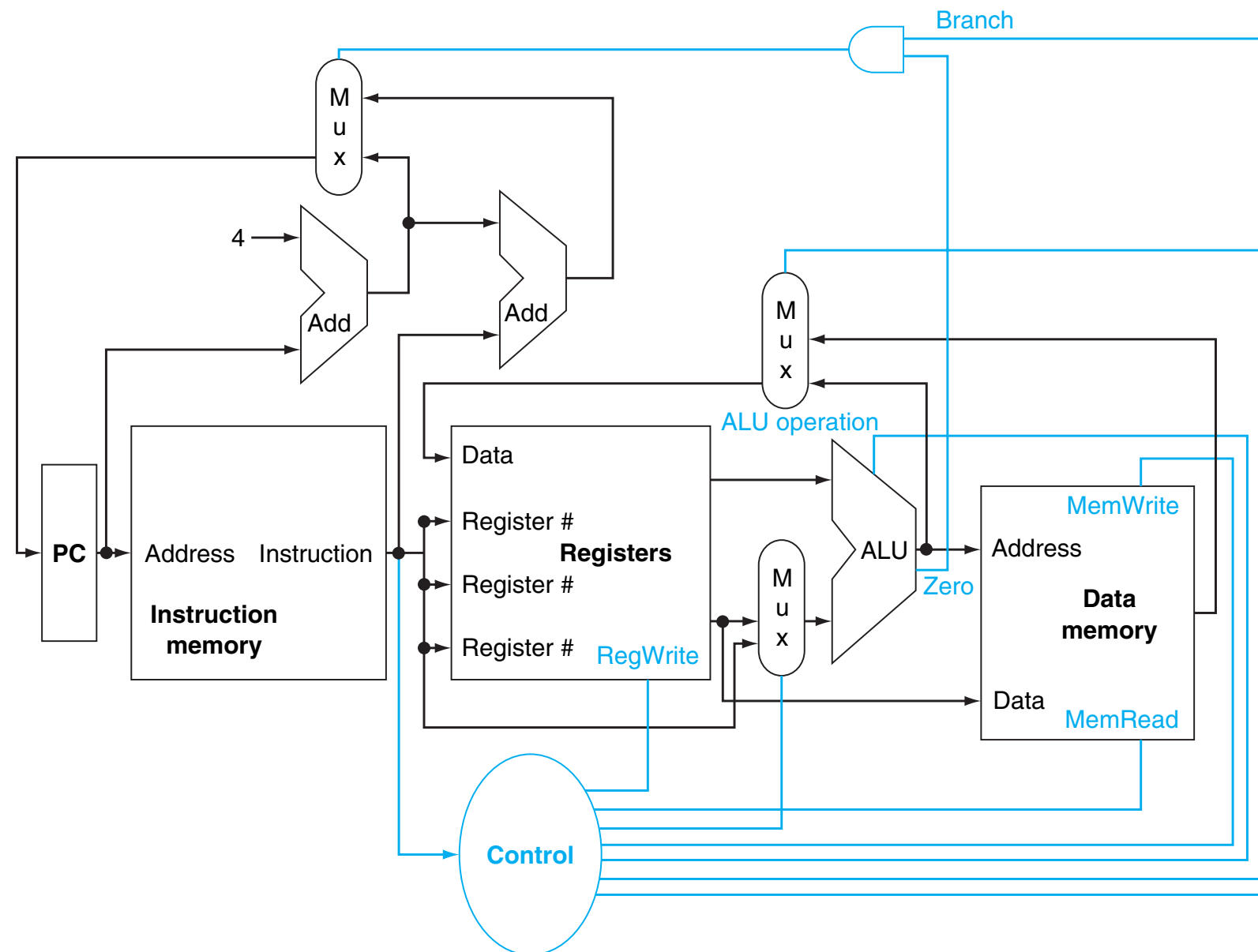

**FIGURE 4.2 The basic implementation of the MIPS subset, including the necessary multiplexors and control lines.**

The top multiplexor (“Mux”) controls what value replaces the PC (PC + 4 or the branch destination address); the multiplexor is controlled by the gate that “ANDs” together the Zero output of the ALU and a control signal that indicates that the instruction is a branch. The middle multiplexor, whose output returns to the register file, is used to steer the output of the ALU (in the case of an arithmetic-logical instruction) or the output of the data memory (in the case of a load) for writing into the register file. Finally, the bottommost multiplexor is used to determine whether the second ALU input is from the registers (for an arithmetic-logical instruction OR a branch) or from the offset field of the instruction (for a load or store). The added control lines are straightforward and determine the operation performed at the ALU, whether the data memory should read or write, and whether the registers should perform a write operation. The control lines are shown in color to make them easier to see. Copyright © 2009 Elsevier, Inc. All rights reserved.



# Combinational Elements

---

- AND gate ( $Y = A \& B$ )

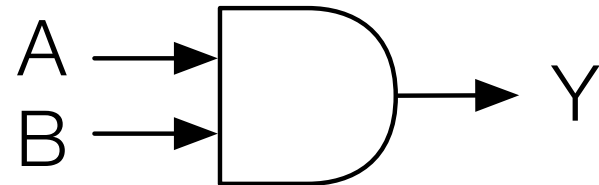

- Adder ( $Y = A + B$ )

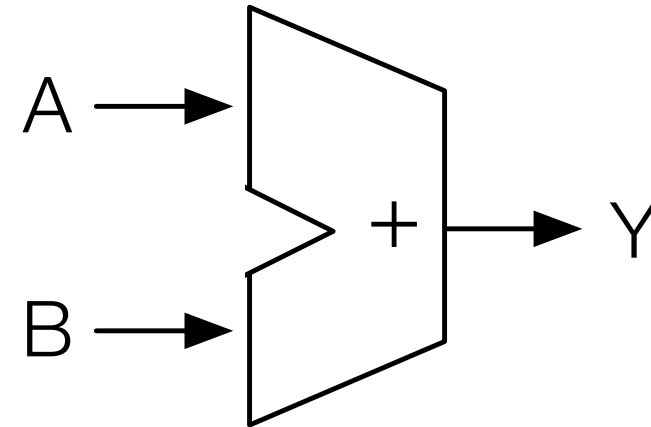

- Multiplexer ( $Y = S ? A : B$ )

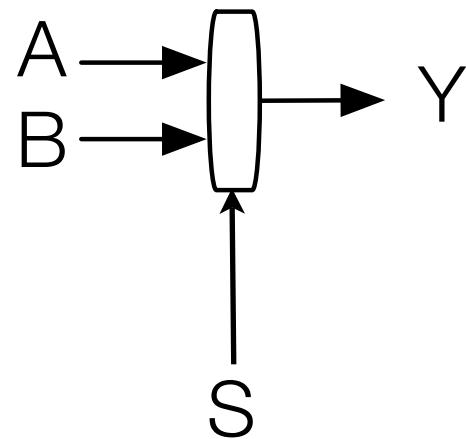

- Arithmetic/Logic Unit (ALU)  
( $Y = F(A,B)$ )

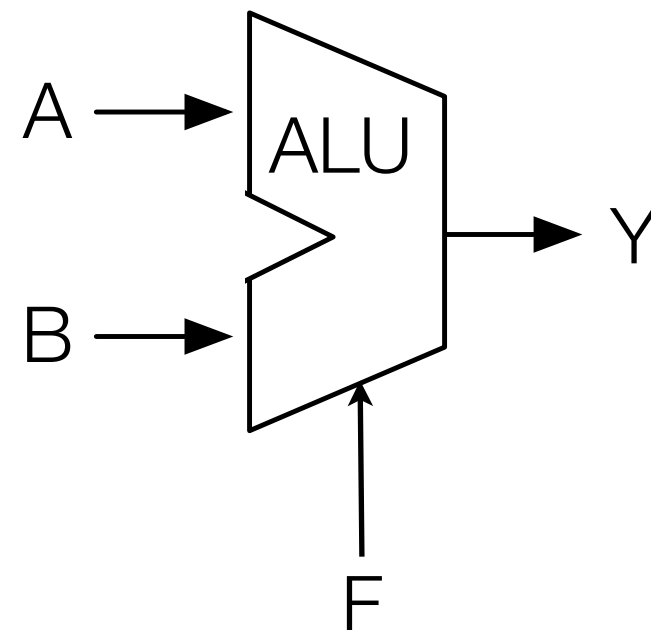

# Clocking Methodology

---

Combinational logic transforms data during clock cycles.  
Longest combinational delay determines clock period.

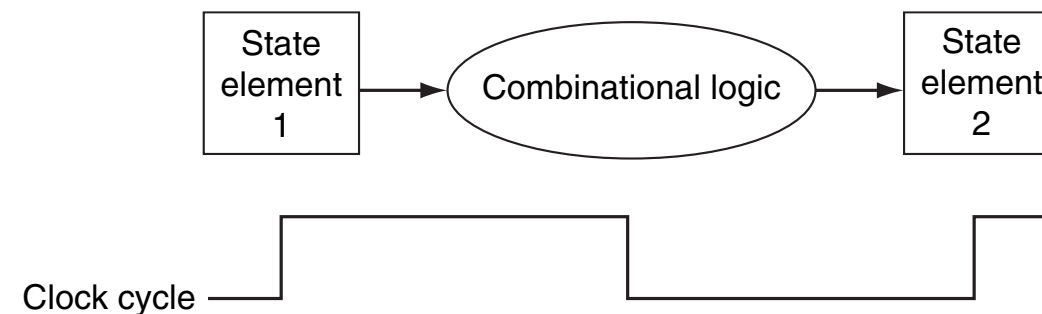

**FIGURE 4.3 Combinational logic, state elements, and the clock are closely related.** In a synchronous digital system, the clock determines when elements with state will write values into internal storage. Any inputs to a state element must reach a stable value (that is, have reached a value from which they will not change until after the clock edge) before the active clock edge causes the state to be updated. All state elements in this chapter, including memory, are assumed to be edge-triggered. Copyright © 2009 Elsevier, Inc. All rights reserved.

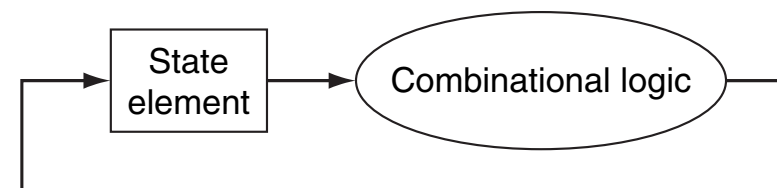

**FIGURE 4.4 An edge-triggered methodology allows a state element to be read and written in the same clock cycle without creating a race that could lead to indeterminate data values.** Of course, the clock cycle still must be long enough so that the input values are stable when the active clock edge occurs. Feedback cannot occur within one clock cycle because of the edge-triggered update of the state element. If feedback were possible, this design could not work properly. Our designs in this chapter and the next rely on the edge-triggered timing methodology and on structures like the one shown in this figure. Copyright © 2009 Elsevier, Inc. All rights reserved.



# Building a datapath incrementally

---

- Datapath: elements that process data and addresses in the CPU
- Datapath will execute one instruction in one clock cycle
  - Each datapath element can only do one function at a time
  - Hence, we need separate instruction and data memories
- Use multiplexers where alternate data sources are used for different instructions

# Instruction Fetch

- Fetch Instruction contained in PC register from memory
- Compute  $PC + 4$  for next instruction

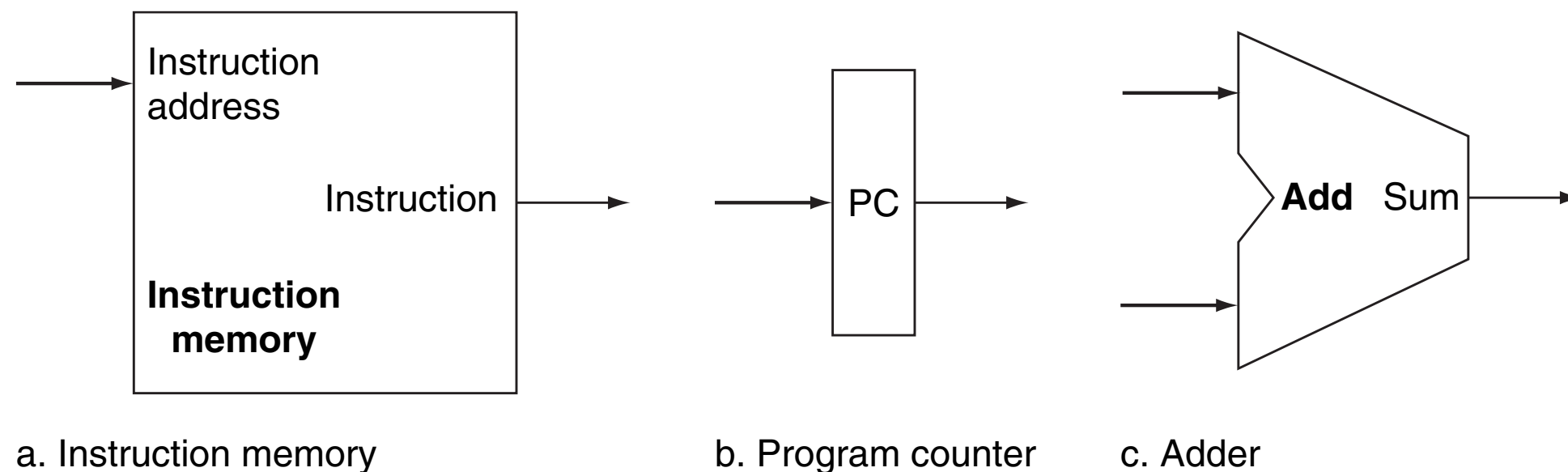

**FIGURE 4.5 Two state elements are needed to store and access instructions, and an adder is needed to compute the next instruction address.** The state elements are the instruction memory and the program counter. The instruction memory need only provide read access because the datapath does not write instructions. Since the instruction memory only reads, we treat it as combinational logic: the output at any time reflects the contents of the location specified by the address input, and no read control signal is needed. (We will need to write the instruction memory when we load the program; this is not hard to add, and we ignore it for simplicity.) The program counter is a 32-bit register that is written at the end of every clock cycle and thus does not need a write control signal. The adder is an ALU wired to always add its two 32-bit inputs and place the sum on its output. Copyright © 2009 Elsevier, Inc. All rights reserved.

# Part 1: Instruction Fetch

---

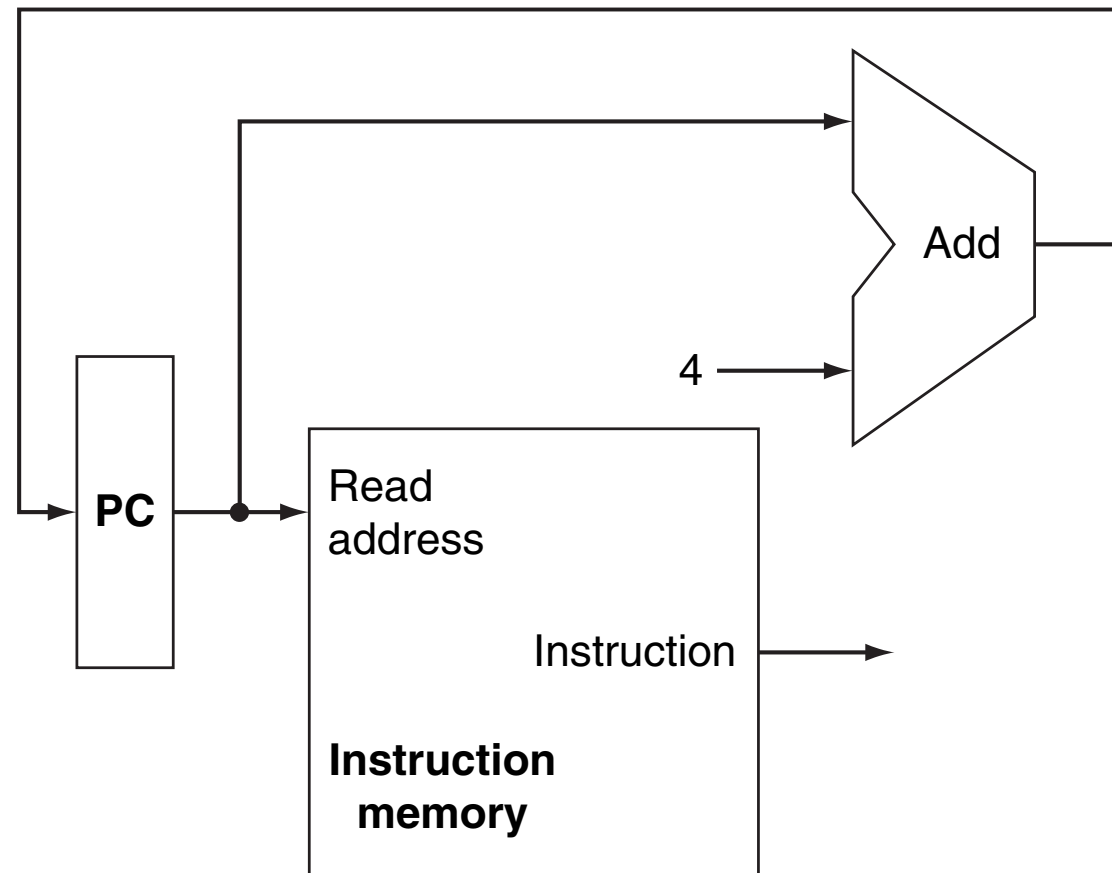

**FIGURE 4.6** A portion of the datapath used for fetching instructions and incrementing the program counter. The fetched instruction is used by other parts of the datapath. Copyright © 2009 Elsevier, Inc. All rights reserved.

# R-Format Instructions

- Read two register operands
- Perform arithmetic/logical operation
- Write register result

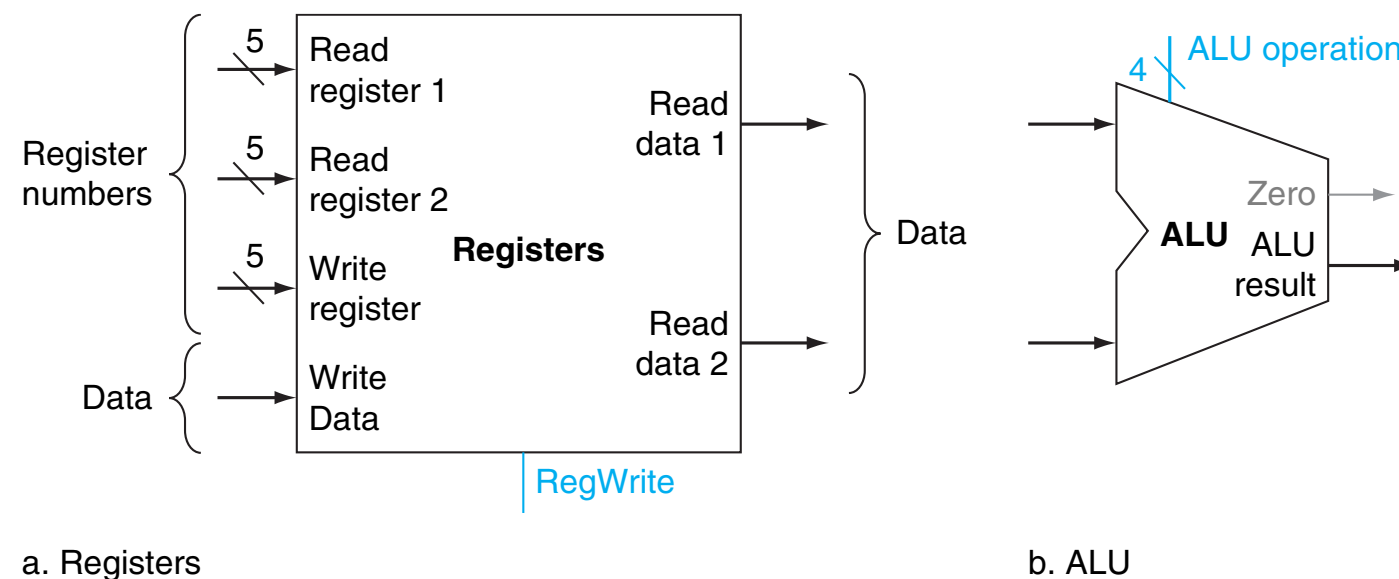

**FIGURE 4.7** The two elements needed to implement R-format ALU operations are the register file and the ALU. The register file contains all the registers and has two read ports and one write port. The design of multiported register files is discussed in Section C.8 of [Appendix C](#). The register file always outputs the contents of the registers corresponding to the Read register inputs on the outputs; no other control inputs are needed. In contrast, a register write must be explicitly indicated by asserting the write control signal. Remember that writes are edge-triggered, so that all the write inputs (i.e., the value to be written, the register number, and the write control signal) must be valid at the clock edge. Since writes to the register file are edge-triggered, our design can legally read and write the same register within a clock cycle: the read will get the value written in an earlier clock cycle, while the value written will be available to a read in a subsequent clock cycle. The inputs carrying the register number to the register file are all 5 bits wide, whereas the lines carrying data values are 32 bits wide. The operation to be performed by the ALU is controlled with the ALU operation signal, which will be 4 bits wide, using the ALU designed in [Appendix C](#). We will use the Zero detection output of the ALU shortly to implement branches. The overflow output will not be needed until Section 4.9, when we discuss exceptions; we omit it until then. Copyright © 2009 Elsevier, Inc. All rights reserved.

# Load/Store Instructions

- Read register operands
- Calculate address using 16-bit offset (sign-extend offset and use ALU)
- Load: read memory and update register
- Store: write register value to memory

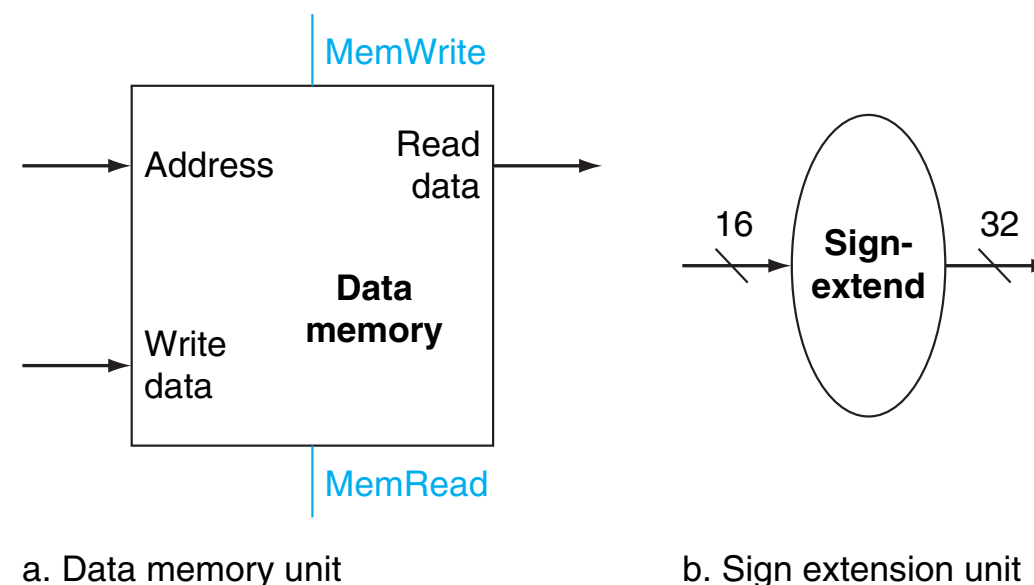

**FIGURE 4.8** The two units needed to implement loads and stores, in addition to the register file and ALU of Figure 4.7, are the data memory unit and the sign extension unit.

The memory unit is a state element with inputs for the address and the write data, and a single output for the read result. There are separate read and write controls, although only one of these may be asserted on any given clock. The memory unit needs a read signal, since, unlike the register file, reading the value of an invalid address can cause problems, as we will see in Chapter 5. The sign extension unit has a 16-bit input that is sign-extended into a 32-bit result appearing on the output (see Chapter 2). We assume the data memory is edge-triggered for writes. Standard memory chips actually have a write enable signal that is used for writes. Although the write enable is not edge-triggered, our edge-triggered design could easily be adapted to work with real memory chips. See Section C.8 of [Appendix C](#) for further discussion of how real memory chips work. Copyright © 2009 Elsevier, Inc. All rights reserved.

# Part 2: R-Type/Load/Store Datapath

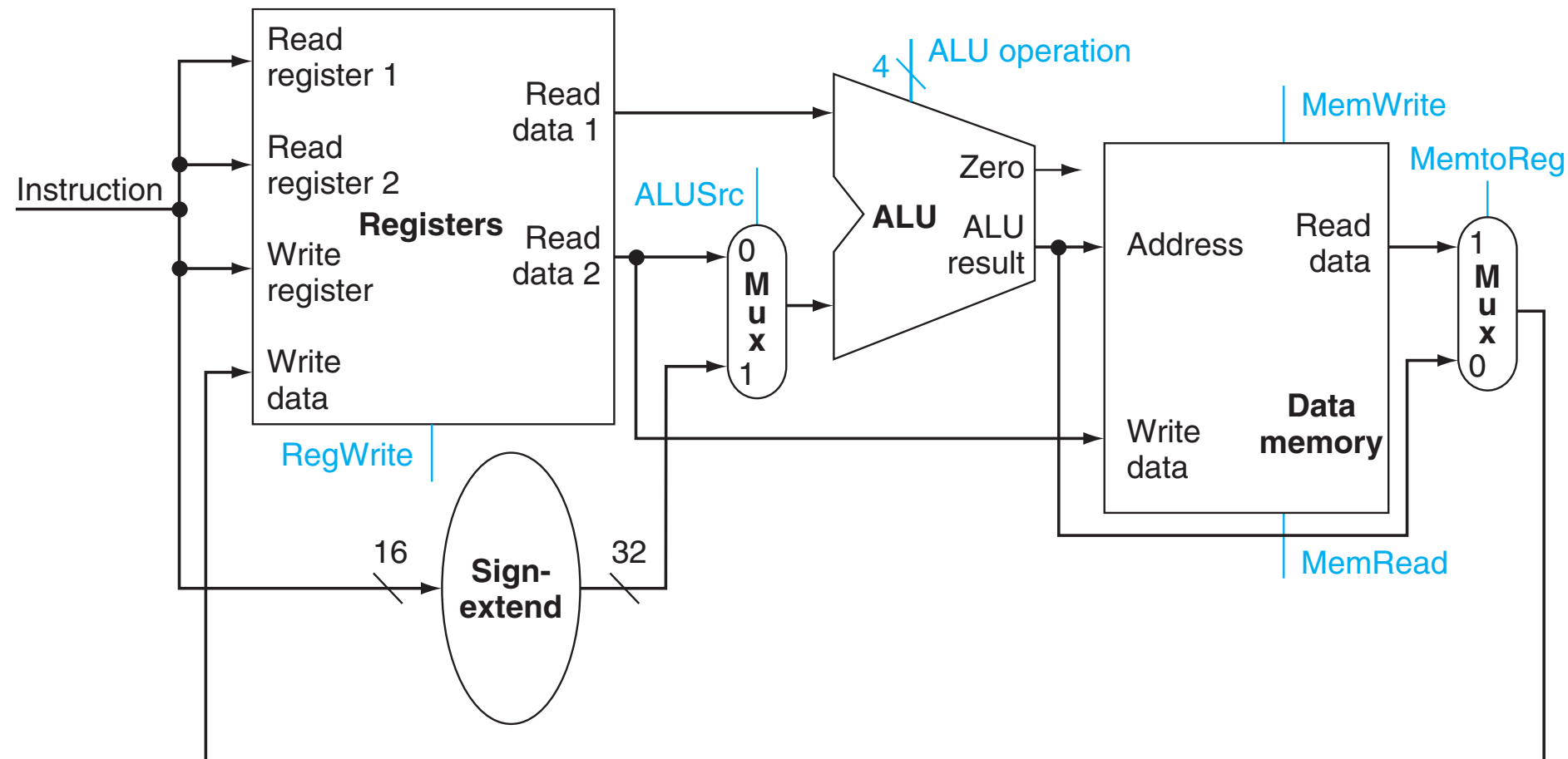

**FIGURE 4.10** The datapath for the memory instructions and the R-type instructions. This example shows how a single datapath can be assembled from the pieces in Figures 4.7 and 4.8 by adding multiplexors. Two multiplexors are needed, as described in the example. Copyright © 2009 Elsevier, Inc. All rights reserved.

# Branch Instructions

---

- Read register operands
- Compare operands (use ALU: subtract and check zero output)
- Calculate target address
  - Sign-extend displacement
  - Shift left two places (word displacement)
  - Add to PC+4 (already calculated by instruction fetch)

# Part 3: Instruction Fetch w. Branch

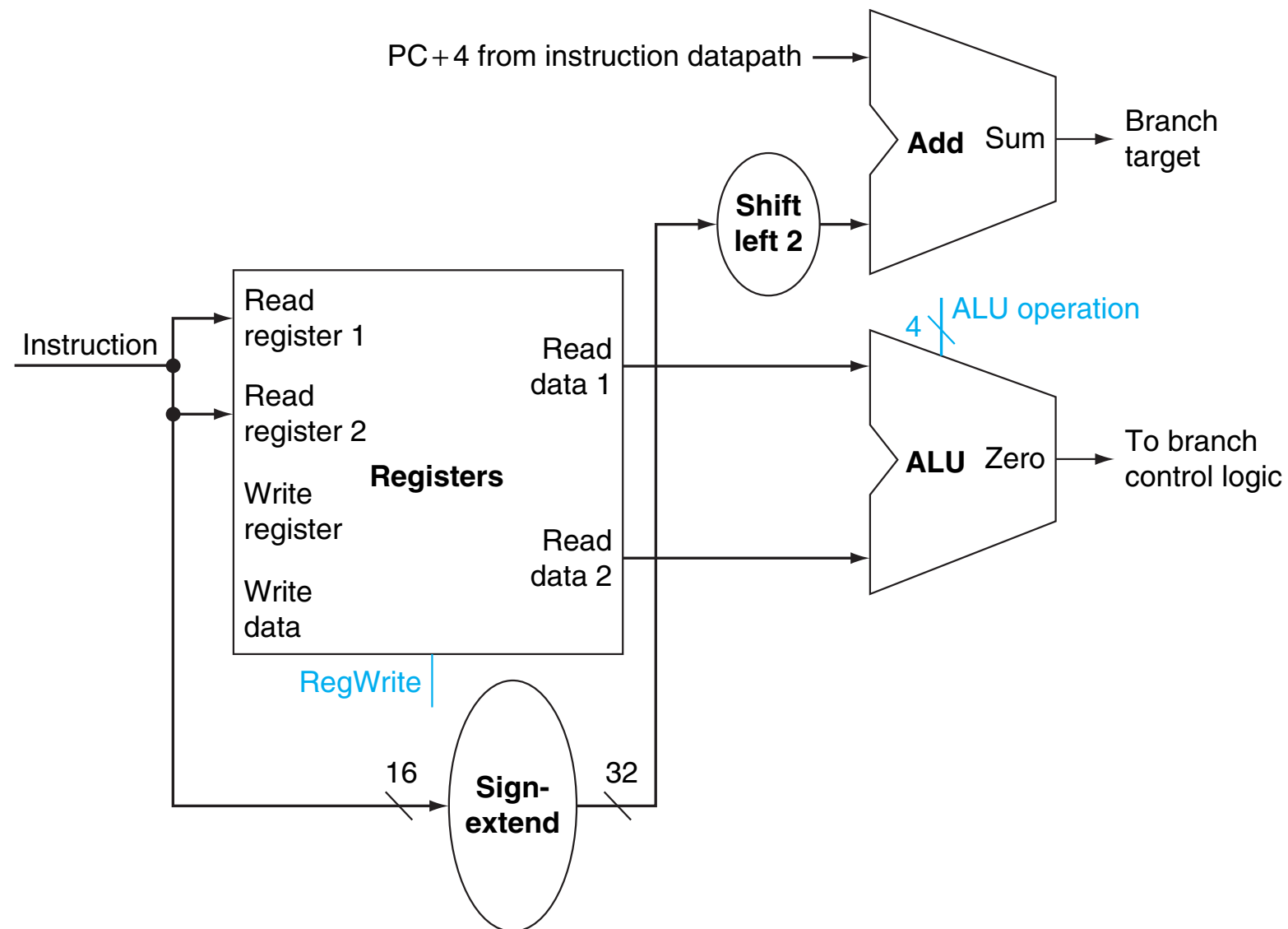

**FIGURE 4.9** The datapath for a branch uses the ALU to evaluate the branch condition and a separate adder to compute the branch target as the sum of the incremented PC and the sign-extended, lower 16 bits of the instruction (the branch displacement), shifted left 2 bits. The unit labeled *Shift left 2* is simply a routing of the signals between input and output that adds  $00_{\text{two}}$  to the low-order end of the sign-extended offset field; no actual shift hardware is needed, since the amount of the “shift” is constant. Since we know that the offset was sign-extended from 16 bits, the shift will throw away only “sign bits.” Control logic is used to decide whether the incremented PC or branch target should replace the PC, based on the Zero output of the ALU. Copyright © 2009 Elsevier, Inc. All rights reserved.



# Full Datapath

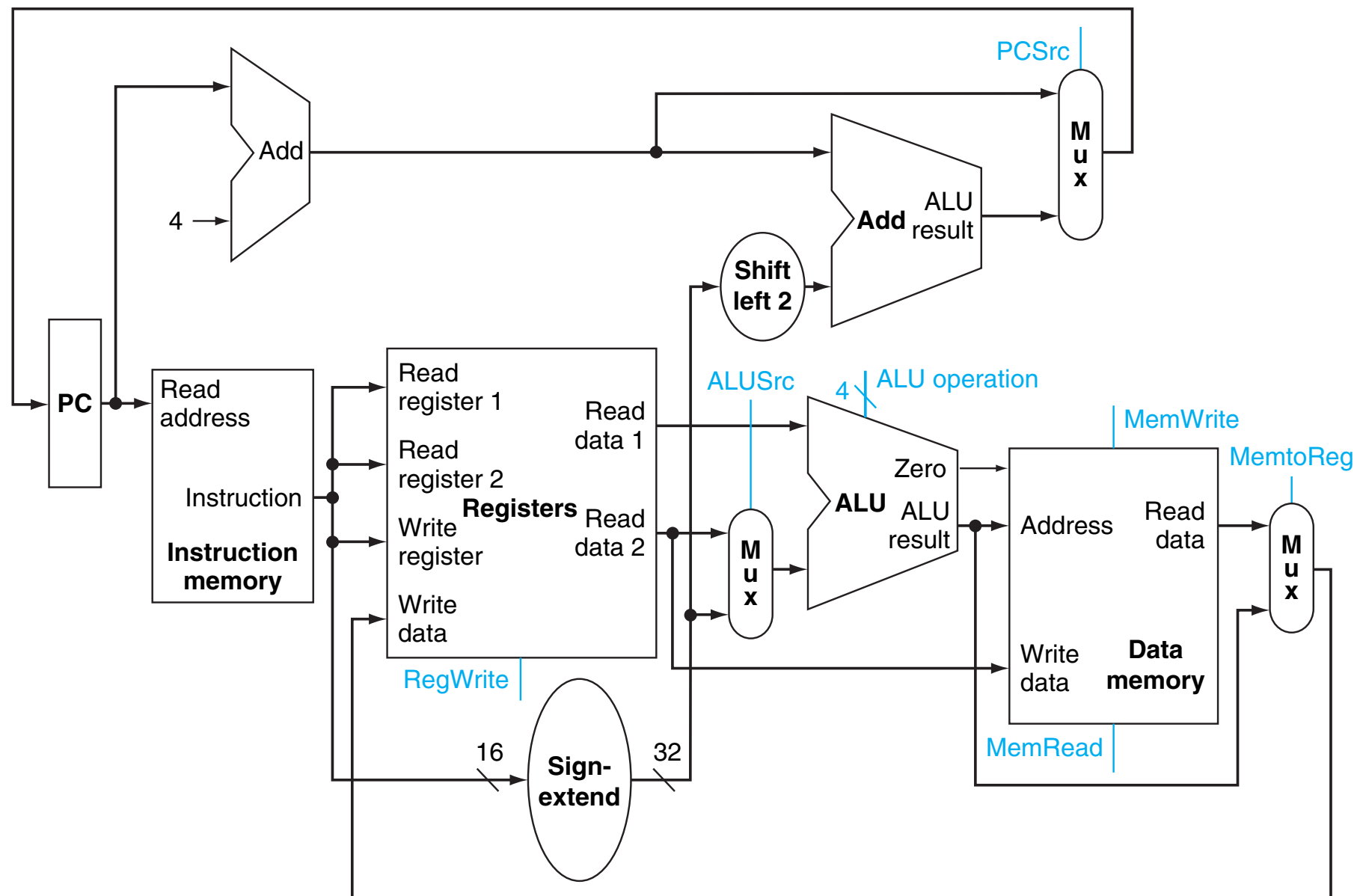

**FIGURE 4.11** The simple datapath for the MIPS architecture combines the elements required by different instruction classes. The components come from Figures 4.6, 4.9, and 4.10. This datapath can execute the basic instructions (load-store word, ALU operations, and branches) in a single clock cycle. An additional multiplexor is needed to integrate branches. The support for jumps will be added later. Copyright © 2009 Elsevier, Inc. All rights reserved.

# Datapath Control Scheme

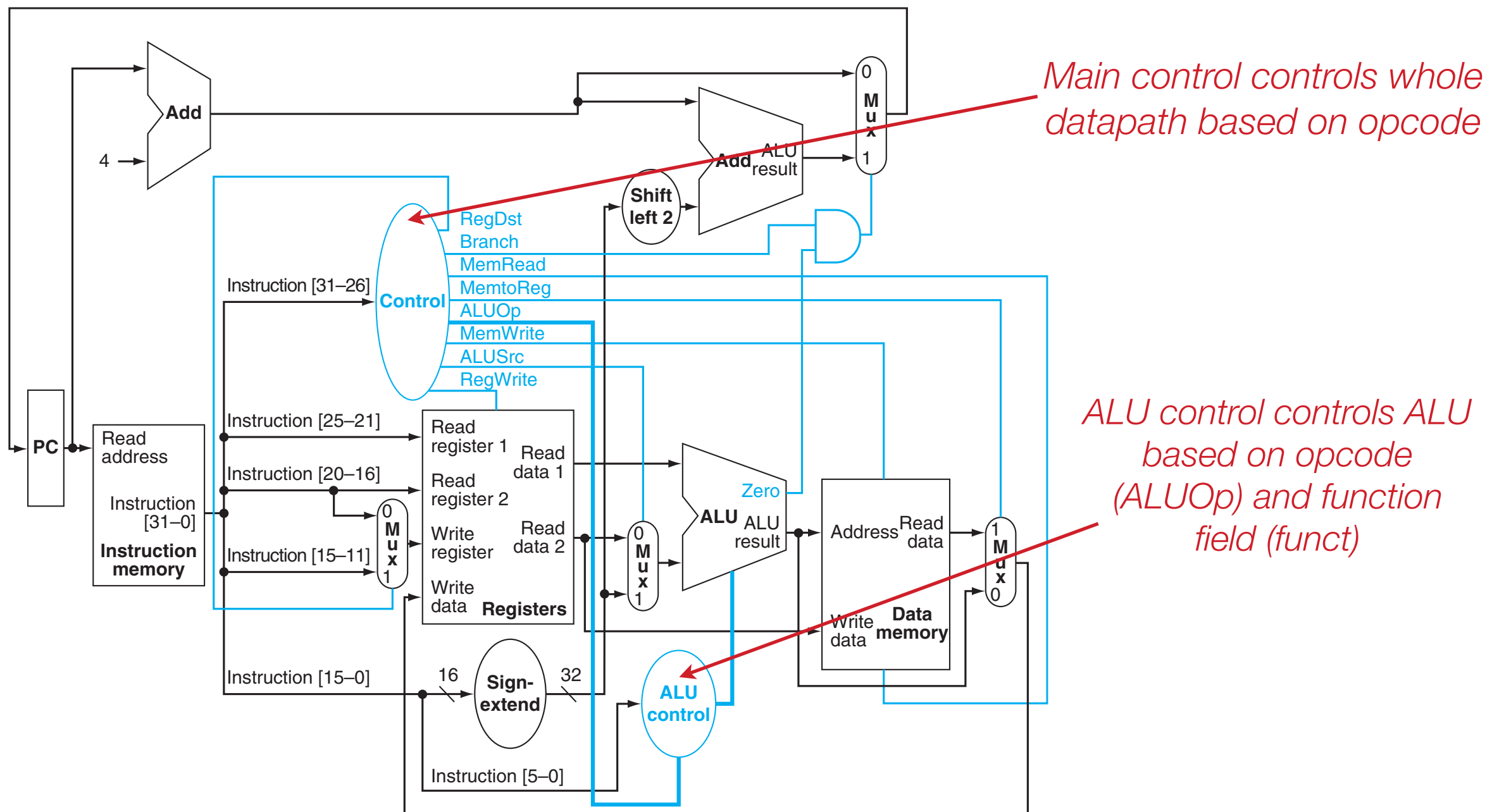

**FIGURE 4.17 The simple datapath with the control unit.** The input to the control unit is the 6-bit opcode field from the instruction. The outputs of the control unit consist of three 1-bit signals that are used to control multiplexers (RegDst, ALUSrc, and MemtoReg), three signals for controlling reads and writes in the register file and data memory (RegWrite, MemRead, and MemWrite), a 1-bit signal used in determining whether to possibly branch (Branch), and a 2-bit control signal for the ALU (ALUOp). An AND gate is used to combine the branch control signal and the Zero output from the ALU; the AND gate output controls the selection of the next PC. Notice that PCSrc is now a derived signal, rather than one coming directly from the control unit. Thus, we drop the signal name in subsequent figures. Copyright © 2009 Elsevier, Inc. All rights reserved.



# ALU Control Inputs/Outputs

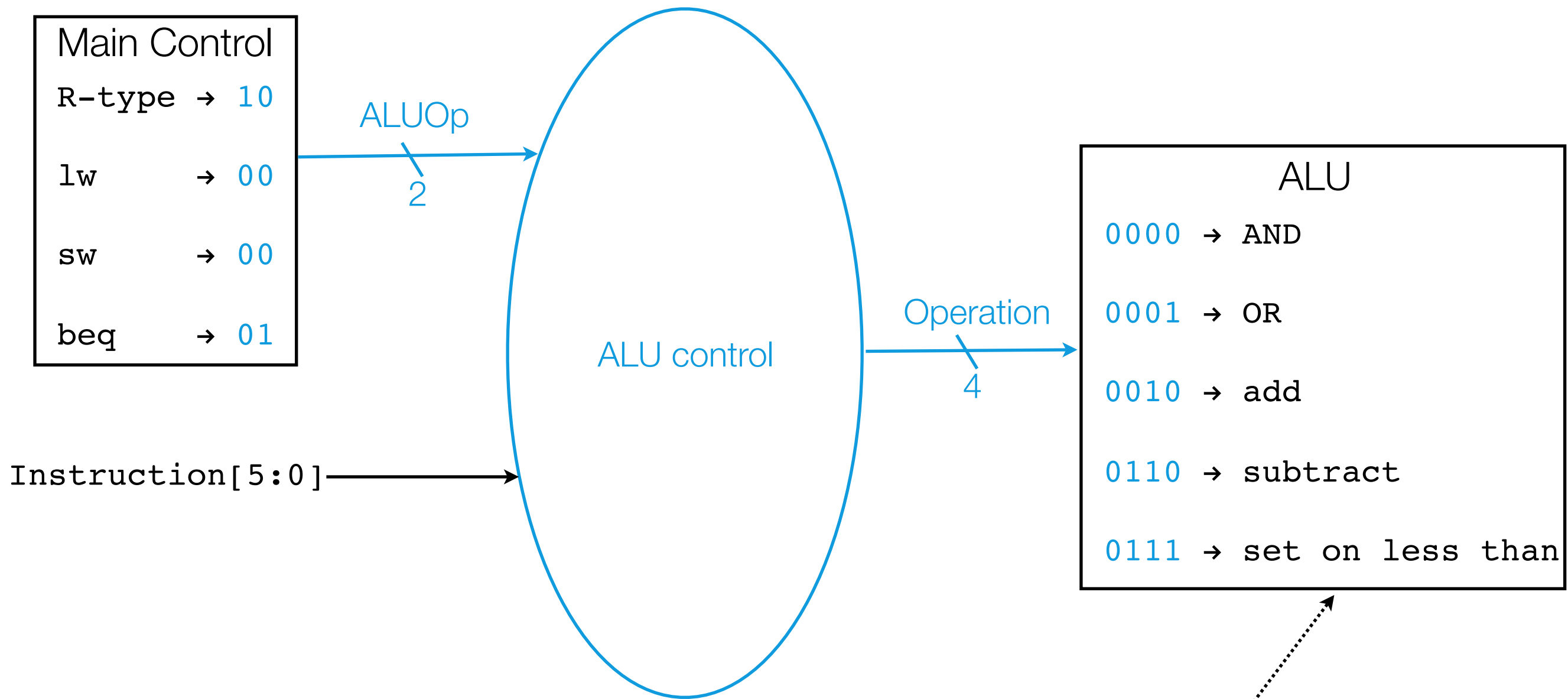

*(See Appendix C of text for implementation of corresponding ALU.)*

# ALU Control Implementation

---

opcode	ALUOp from main control	Instruction[5:0]		Operation
lw	→ 00	xxxxxx → load word	→ add	→ 0010
sw	→ 00	xxxxxx → store word	→ add	→ 0010
beq	→ 01	xxxxxx → branch equal	→ subtract	→ 0110
R-type	→ 10	100000 → add	→ add	→ 0010
R-type	→ 10	100010 → subtract	→ subtract	→ 0110
R-type	→ 10	100100 → AND	→ AND	→ 0000
R-type	→ 10	100101 → OR	→ OR	→ 0001
R-type	→ 10	101010 → set on less than	→ set on less than	→ 0111

# ALU Control Truth Table

---

ALUOp from main control	Instruction[5:0]	Operation
00	xxxxxxx	0010
00	xxxxxxx	0010
01	xxxxxxx	0110
10	100000	0010
10	100010	0110
10	100100	0000
10	100101	0001
10	101010	0111

# ALU Control Truth Table 2

ALUOp		Funct field						Operation
ALUOp1	ALUOp0	F5	F4	F3	F2	F1	F0	
0	0	X	X	X	X	X	X	0010
0	1	X	X	X	X	X	X	0110
1	0	X	X	0	0	0	0	0010
1	X	X	X	0	0	1	0	0110
1	0	X	X	0	1	0	0	0000
1	0	X	X	0	1	0	1	0001
1	X	X	X	1	0	1	0	0111

**FIGURE 4.13 The truth table for the 4 ALU control bits (called Operation).** The inputs are the ALUOp and function code field. Only the entries for which the ALU control is asserted are shown. Some don't-care entries have been added. For example, the ALUOp does not use the encoding 11, so the truth table can contain entries 1X and X1, rather than 10 and 01. Note that when the function field is used, the first 2 bits (F5 and F4) of these instructions are always 10, so they are don't-care terms and are replaced with XX in the truth table. Copyright © 2009 Elsevier, Inc. All rights reserved.

# Datapath Control Scheme

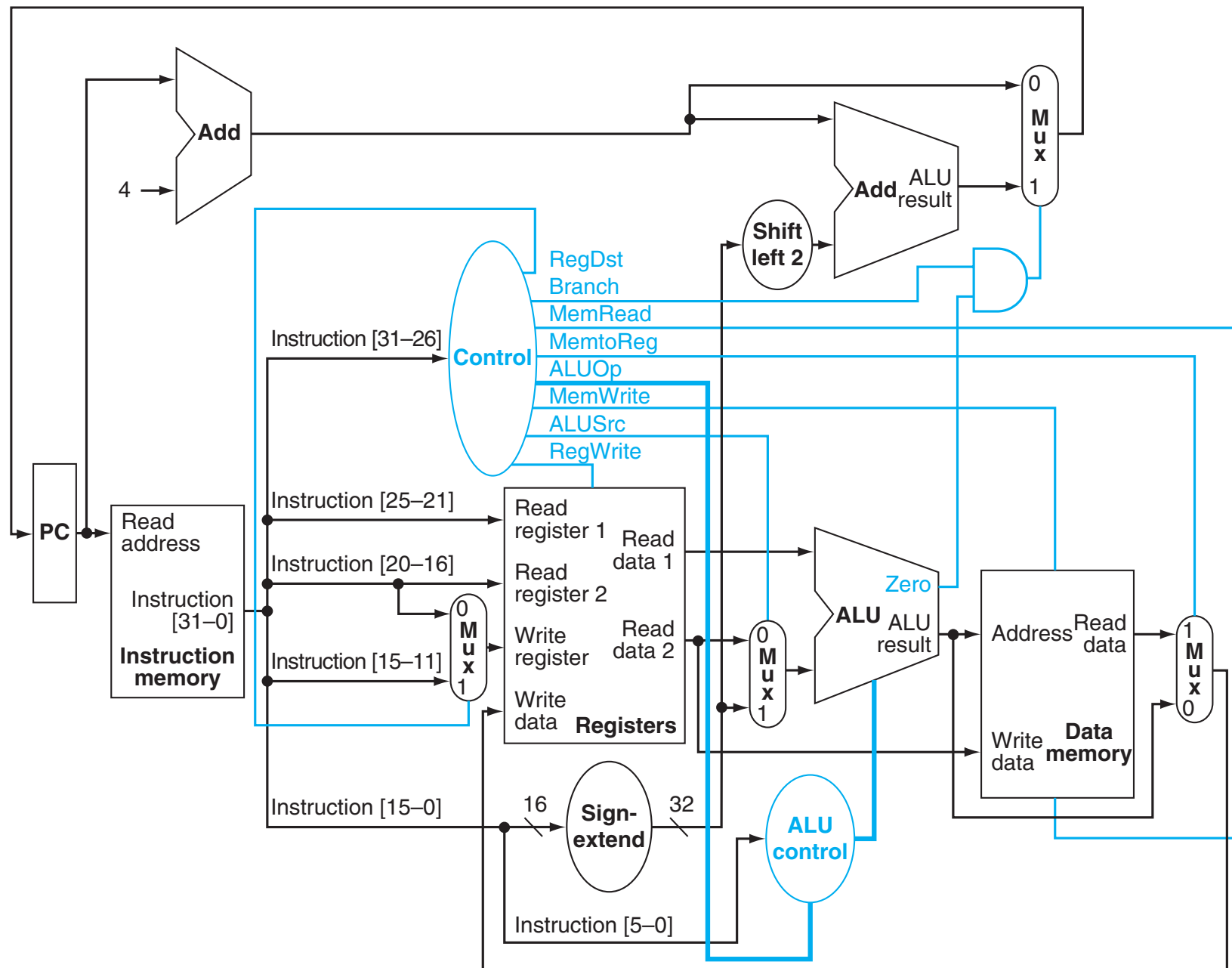

**FIGURE 4.17 The simple datapath with the control unit.** The input to the control unit is the 6-bit opcode field from the instruction. The outputs of the control unit consist of three 1-bit signals that are used to control multiplexers (RegDst, ALUSrc, and MemtoReg), three signals for controlling reads and writes in the register file and data memory (RegWrite, MemRead, and MemWrite), a 1-bit signal used in determining whether to possibly branch (Branch), and a 2-bit control signal for the ALU (ALUOp). An AND gate is used to combine the branch control signal and the Zero output from the ALU; the AND gate output controls the selection of the next PC. Notice that PCSrc is now a derived signal, rather than one coming directly from the control unit. Thus, we drop the signal name in subsequent figures. Copyright © 2009 Elsevier, Inc. All rights reserved.

# Main control signals derive from instruction types

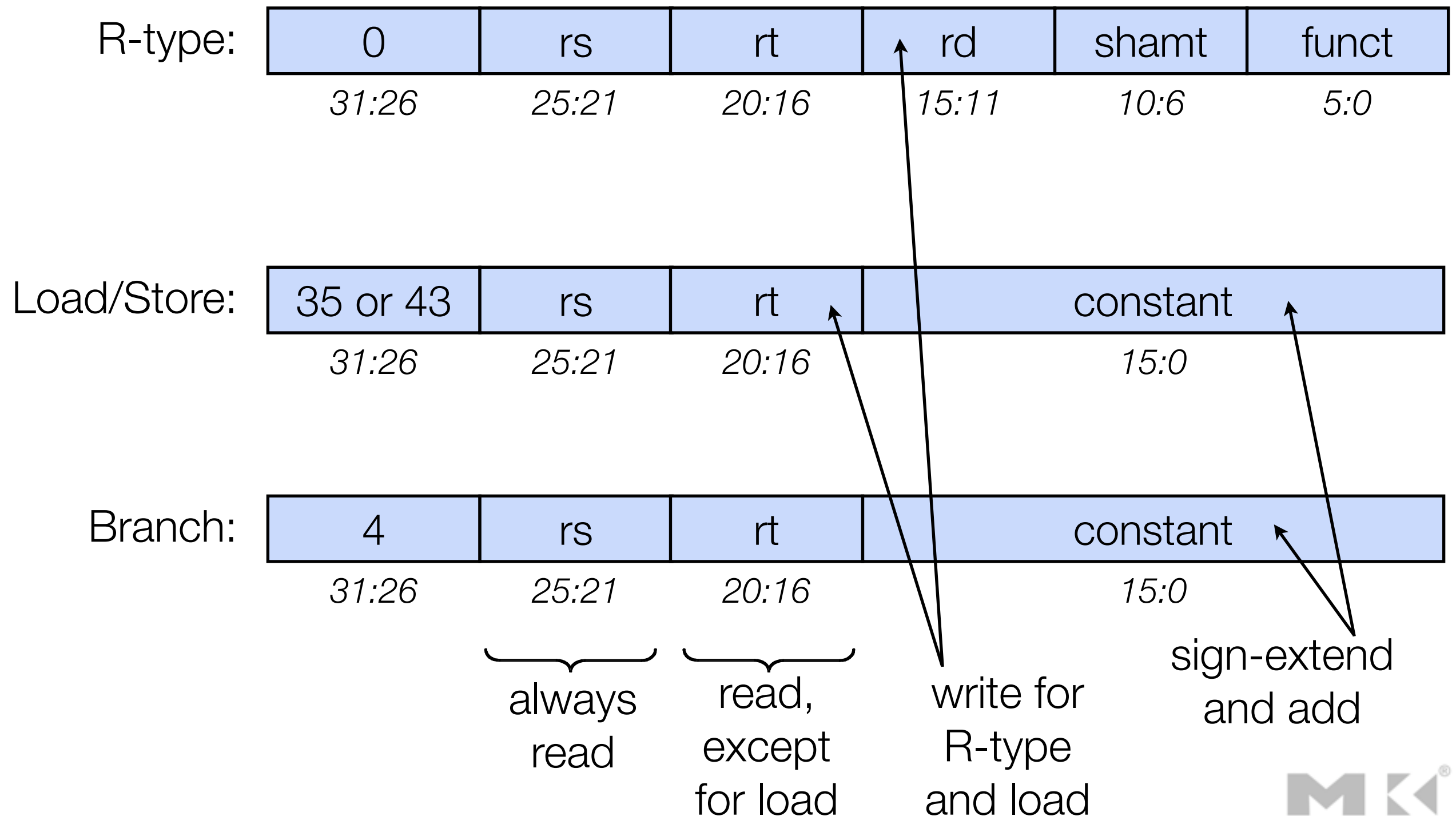



# R-Type Control Signals

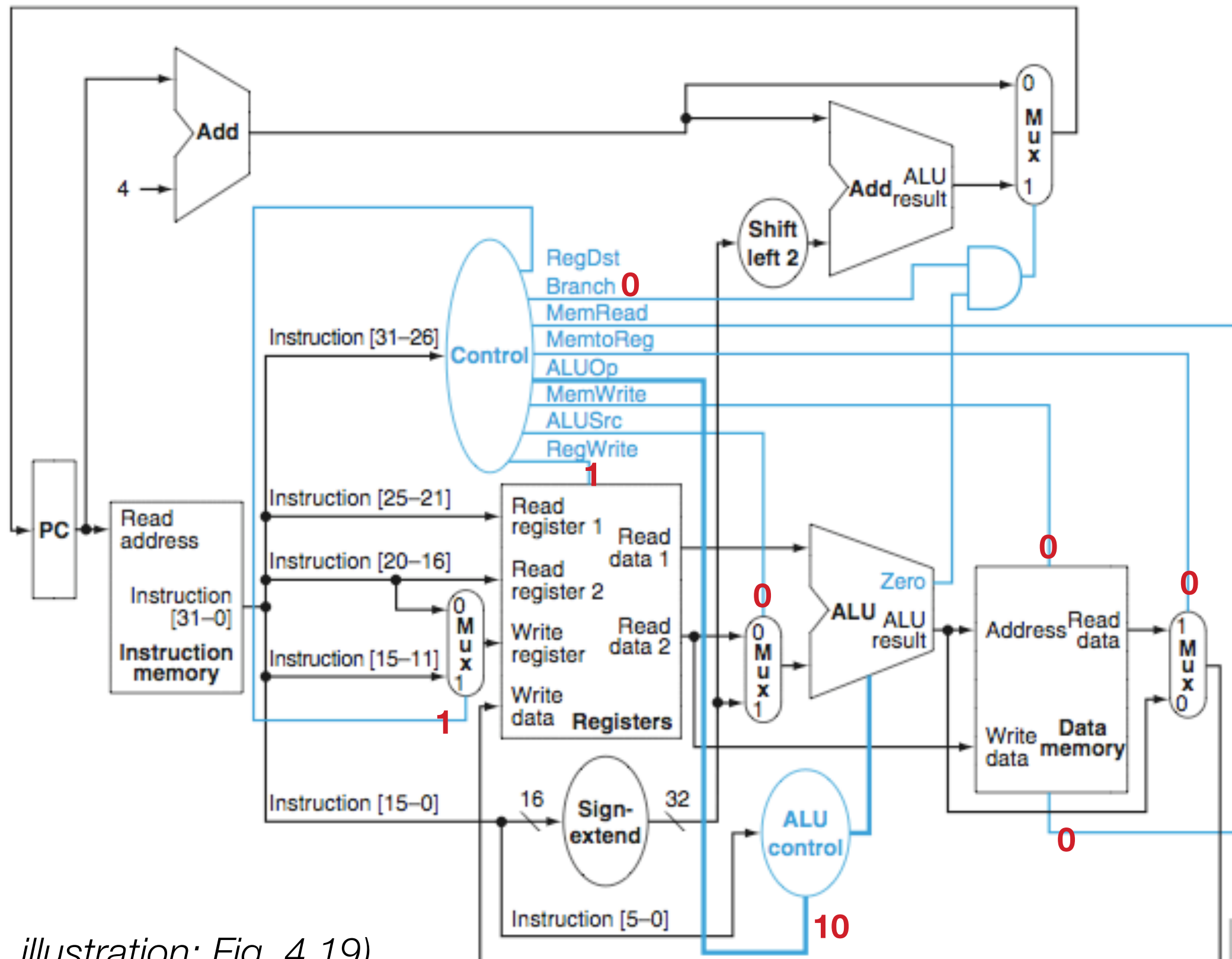

(Alt. illustration: Fig. 4.19)



# 1w Control Signals

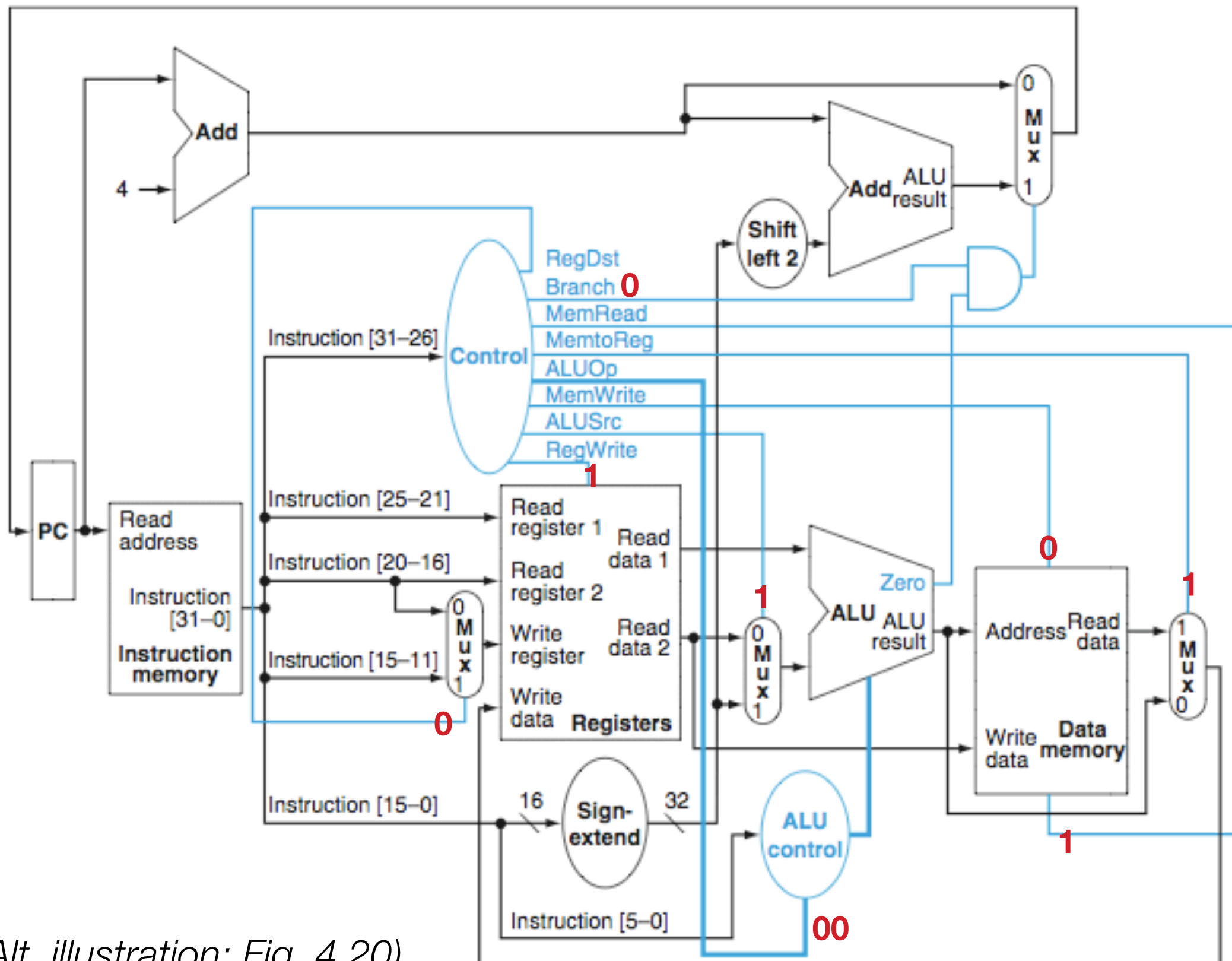

(Alt. illustration: Fig. 4.20)



# sw Control Signals

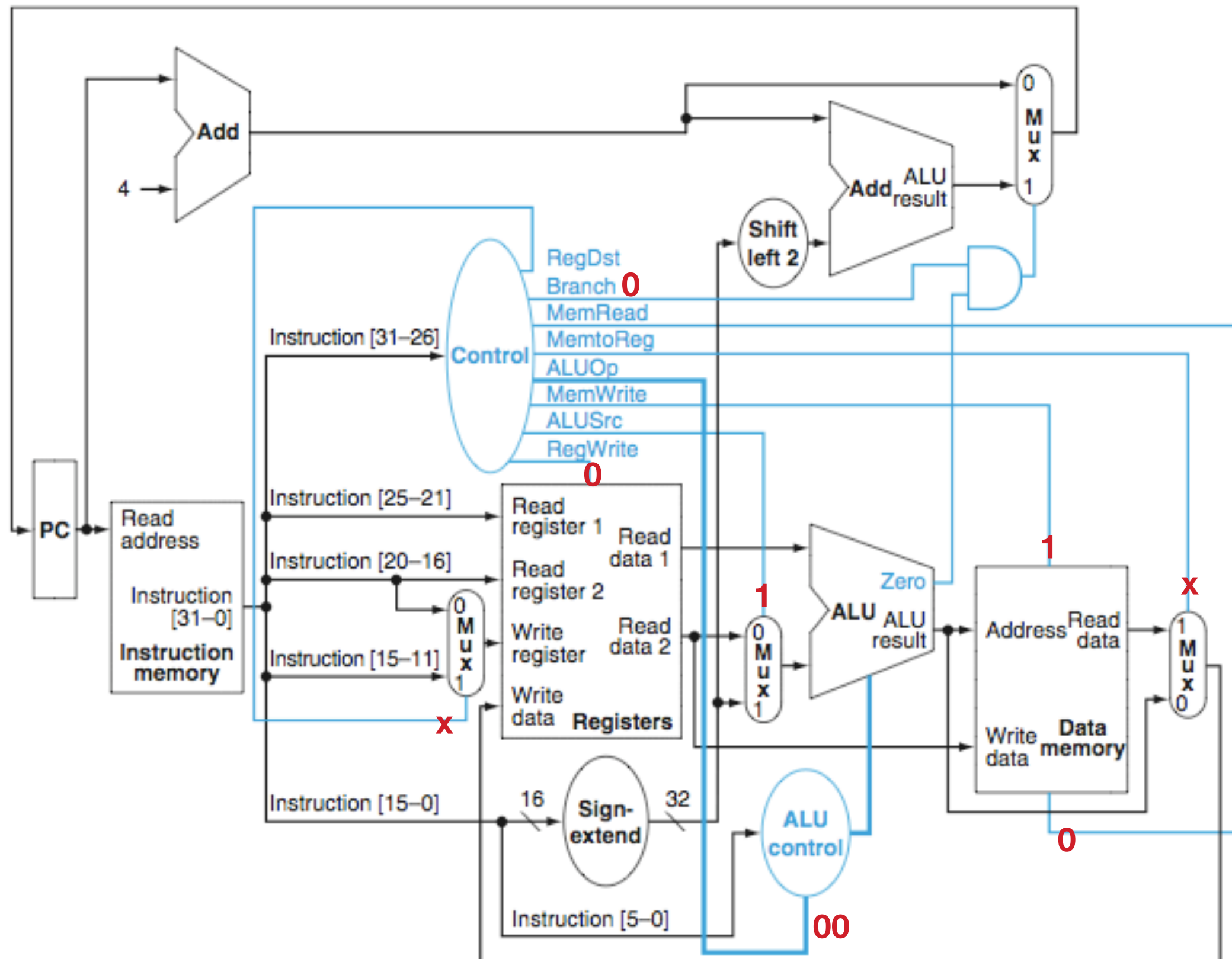

# beq Control Signals

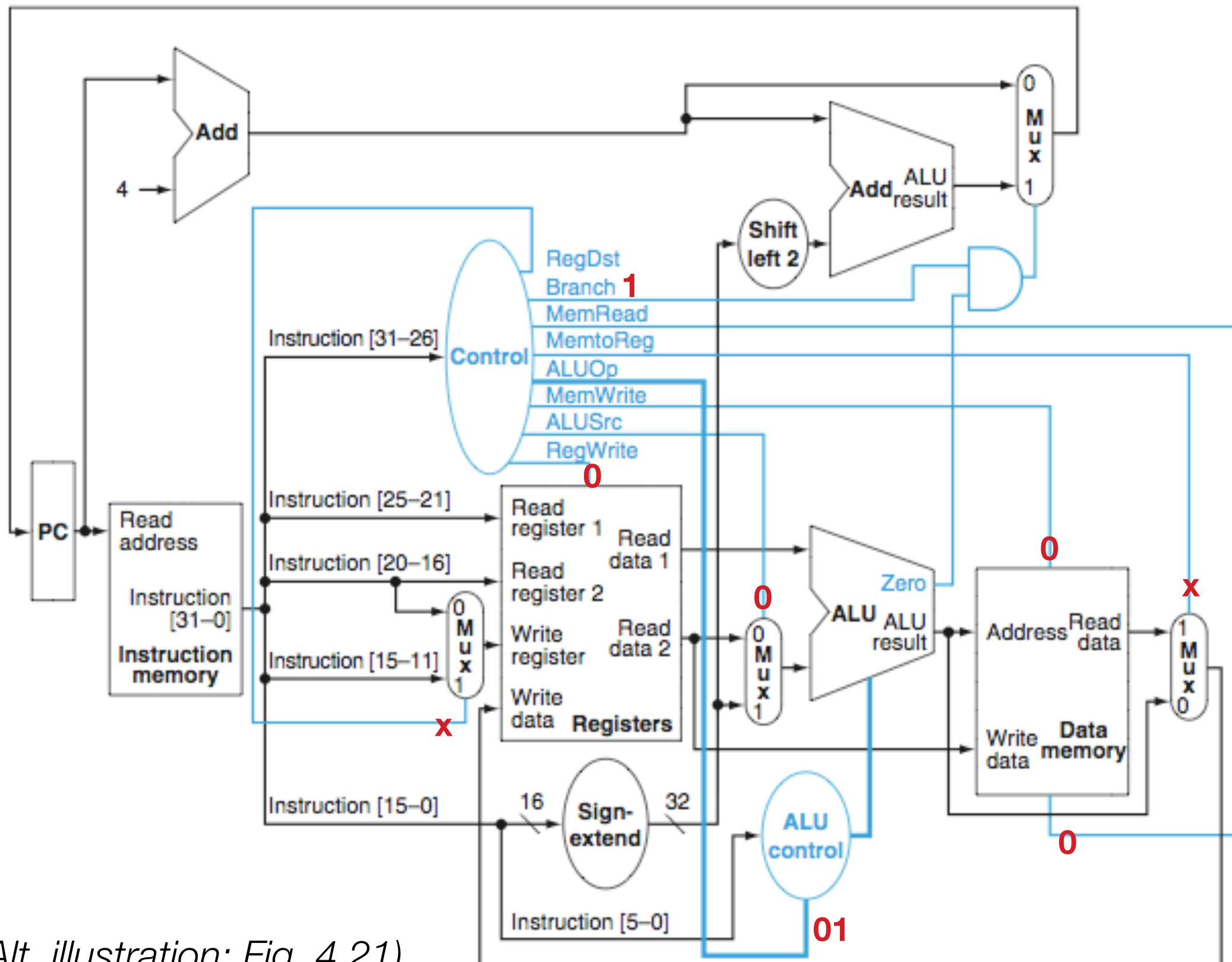

(Alt. illustration: Fig. 4.21)



# Main Control Truth Table

Instruction[31:26]

	Instruction	RegDst	ALUSrc	Memto-Reg	Reg-Write	Mem-Read	Mem-Write	Branch	ALUOp1	ALUOp0
000000	R-format	1	0	0	1	0	0	0	1	0
100011	lw	0	1	1	1	1	0	0	0	0
101011	sw	X	1	X	0	0	1	0	0	0
000100	beq	X	0	X	0	0	0	1	0	1

**FIGURE 4.18 The setting of the control lines is completely determined by the opcode fields of the instruction.** The first row of the table corresponds to the R-format instructions (add, sub, AND, OR, and slt). For all these instructions, the source register fields are rs and rt, and the destination register field is rd; this defines how the signals ALUSrc and RegDst are set. Furthermore, an R-type instruction writes a register (RegWrite = 1), but neither reads nor writes data memory. When the Branch control signal is 0, the PC is unconditionally replaced with PC + 4; otherwise, the PC is replaced by the branch target if the Zero output of the ALU is also high. The ALUOp field for R-type instructions is set to 10 to indicate that the ALU control should be generated from the funct field. The second and third rows of this table give the control signal settings for lw and sw. These ALUSrc and ALUOp fields are set to perform the address calculation. The MemRead and MemWrite are set to perform the memory access. Finally, RegDst and RegWrite are set for a load to cause the result to be stored into the rt register. The branch instruction is similar to an R-format operation, since it sends the rs and rt registers to the ALU. The ALUOp field for branch is set for a subtract (ALU control = 01), which is used to test for equality. Notice that the MemtoReg field is irrelevant when the RegWrite signal is 0: since the register is not being written, the value of the data on the register data write port is not used. Thus, the entry MemtoReg in the last two rows of the table is replaced with X for don't care. Don't cares can also be added to RegDst when RegWrite is 0. This type of don't care must be added by the designer, since it depends on knowledge of how the datapath works. Copyright © 2009 Elsevier, Inc. All rights reserved.

# The j instruction

---

- Unconditional jump to instruction at `label`

`j label`

- Instruction encoded in J-type format



- Jump uses word addresses
- Update PC with concatenation of:
  - Top 4 bits of old PC
  - 26-bit jump address
  - 00

# Implementing the jump instruction

