

# Voice over IP

Henning Schulzrinne  
Columbia University, New York  
schulzrinne@cs.columbia.edu

©1998-2001, Henning Schulzrinne; updated August 12, 2001

# Overview

---

- new Internet services: “telephone”, “radio”, “television”
- why Internet telephony?
- why not already?
- Internet telephony modalities
- components needed:
  - audio coding
  - data transport
  - quality of service – resource reservation
  - signaling
  - PSTN interworking: gateway location, number translation

## New Internet services

---

- tougher: replacing dedicated electronic media
- distribution media: hard to beat one antenna tower for millions of \$30 receivers
- typewriter model of development
- radio, TV, telephone: a (protocol) convergence?

# The phone works — why bother with VoIP?

---

## user perspective

- variable compression: tin can to broadcast quality
- security through encryption
- caller, talker identification
- better user interface
- internat. calls: TAT transatlantic cable = \$0.03/hr
- no local access fees (but ↓ 1c/min.)
- easy: video, whiteboard, ...

## carrier perspective

- silence suppression  $\Rightarrow$  traffic ↓
- shared facilities  $\Rightarrow$  management, redundancy
- advanced services (simpler than AIN and CTI)
- operational advantages
- cheaper switching
- fax as data

## The new phone companies

---

- separation bit carriage  $\leftrightarrow$  services
- anybody with Internet connection can provide services (ACD, 800, 900, directory, ...)
- distinction “in” vs. “out” of network not useful
- incremental start-up investment not large
- new players:
  - cable companies  $\Rightarrow$  no new infrastructure, but mostly one-way
  - electric utilities  $\Rightarrow$  need line management anyway
  - Qwest, IXC (resell to ISPs), ...

## Use VoIP – go to jail

---

**Prohibited:** Albania, Bahrain, Botswana, Burundi, Cuba, Cyprus, India, Jordan, Kenya, Mauritius, Mexico, Nepal, Pakistan, Panama, Slovakia, South Africa, Thailand, Turkey, Venezuela, Vietnam, Yemen.

**Restricted:** Hungary (delay  $> 250$  ms), Brazil, China (China Telecom, 4 spin-offs), Czech Republic (not phone-to-phone), Paraguay (fax only), Poland (p2p for mobile operators)

**Allowed:** Australia, Canada, European Union, Hong Kong, Japan, New Zealand, Peru, Republic of Korea, Singapore, Switzerland, U.S.

(1999 survey)

## Internet telephony as PBX replacement

---

If global Internet not quite ready  $\Rightarrow$  try as PBX

- have mission-critical LAN, PCs anyway
- usually ample (if switched) bandwidth, low latency
- packet switching is cheaper
- network PCs  $\stackrel{\$}{\approx}$  ISDN phones
- no need for billing

## Internet telephony services

---

- voice mail → email
- calendar integration
- user-programmable call processing logic
- call first available sales person (ACD)
- call whole department
- web IVR
- return web page with favorite “on hold” music



## Internet telephony services

---

- camp-on without holding a line
- short message service (“instant messaging”)
- schedule call into the future
- call with expiration date
- add/remove parties to/from call  mesh
- “buddy lists”

## Switching costs

---

switching method	ports	capacity (Gb/s)	cents/64 kb/s	\$/interface
10/100BaseT Ethernet hub	24	2.40	0.6	10.00
100BaseTX Ethernet switch	24	2.40	0.9	14.60
PBX	256	0.02	218.	140
Lucent 5ESS local (no AIN)	5,000	0.32	469.	300
Lucent 5ESS local (AIN)	20,000	1.28	273.	175
Lucent 4ESS toll	100,000	6.40	7.8	

# Telephone costs

---

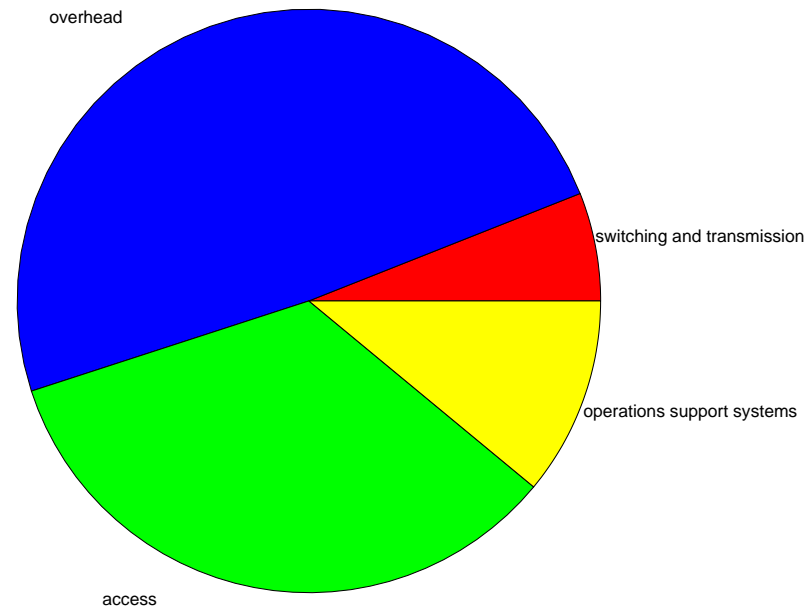

infrastructure	10-23%
switching and transmission	6%
overhead	49%
access	34%
operations support systems	11%

## Transport costs

---

network	\$/min	\$/MB
wholesale telephone	0.01–0.02	
U.S. domestic interstate consumer rates	0.05–0.15	
U.S. domestic intrastate consumer rates	0.05–0.25	
<hr style="border: 1px solid black;"/>		
modem		0.25 – 0.50
private line		0.50 – 1.00
frame relay		0.30
MCI frame SVC		0.05
Internet		0.04 – 0.15
Internet modem		0.33
Internet backbone		0.01

1' voice = 480 kB w/silence suppr., 1 MB without

## Phone usage

---

“Free” phone calls does not mean unbounded increase:

year	lines (millions)	local calls min/day/line	local calls min/day/person
1980	102.2	39	17.5
1988	127.1	39	20.2
1996	166.3	40	25.1

## Traffic (1998)

---

Measured in Dial Equipment Minutes (DEM) or bandwidth:

	GDEM	bandwidth (Gb/s)
Local	2986	364
U.S. intrastate toll	422	51
U.S. interstate toll	555	68

PBX: typically, about 10% utilization per phone  $\Rightarrow$  6.4 kb/s per employee (128 Mb/s for 20,000 person campus)

## Why aren't we junking switches right now?

---

What made other services successful?

**email:** available within self-contained community (CS, EE)

**web:** initially used for local information

**IM:** instantly available for all of AOL

All of these ...

- work with bare-bones connectivity ( $\geq 14.4$  kb/s)
- had few problems with firewalls and NATs
- don't require a reliable network

## Why aren't we junking switches right now?

---

Telephone services are different:

- reliability expectation 99.9% ↗ 99.999%
- PC not well suited for making/receiving calls – most residential handsets are cordless or mobile
- business sets: price incentive minor for non-800 businesses
- services, multimedia limited by PSTN interconnection
- initial incentive of access charge bypass fading (0.5c/min.)
- international calls only outside Western Europe and U.S.



# Data vs. Voice Traffic

---

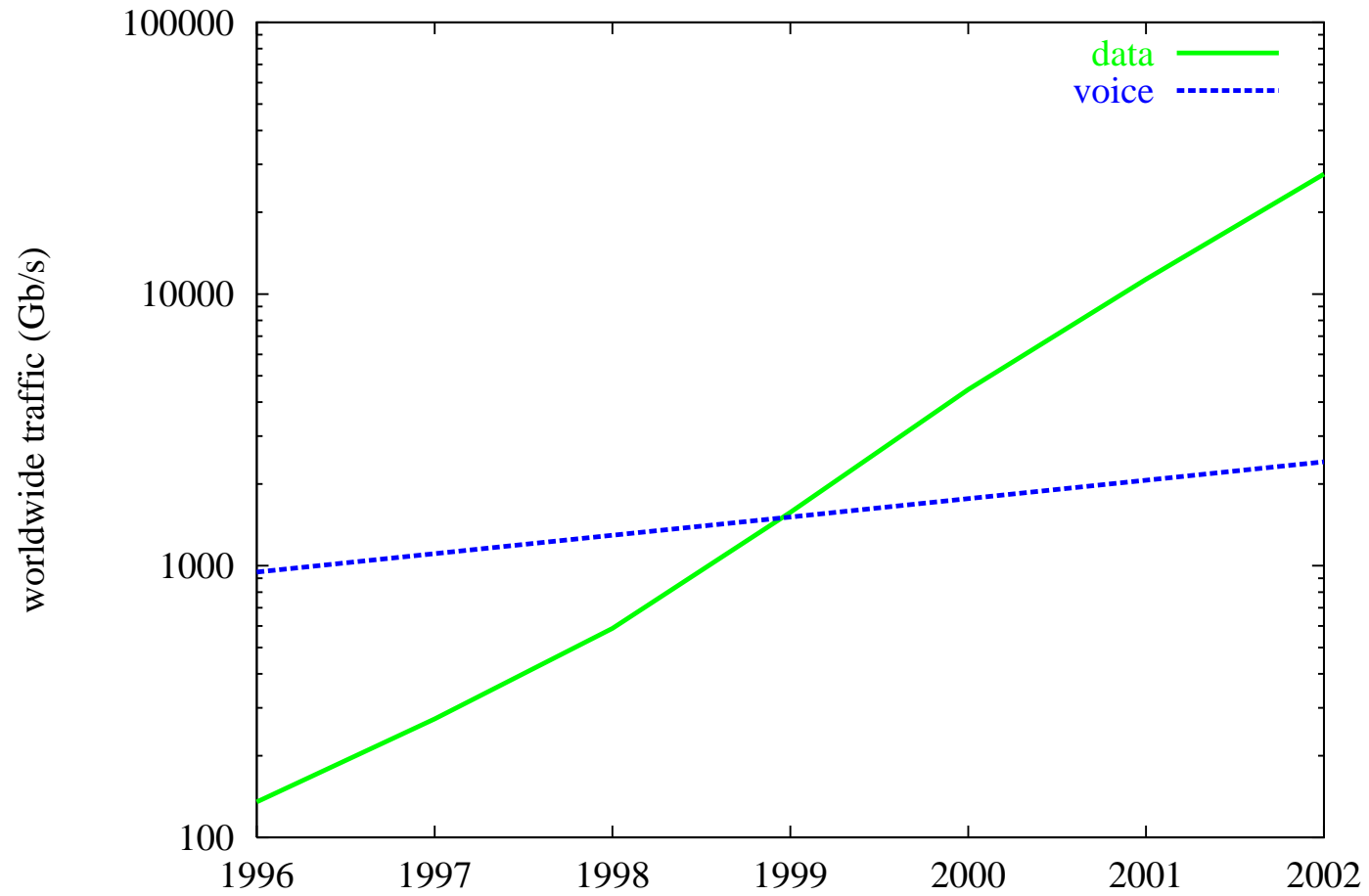

# Internet multimedia protocol stack

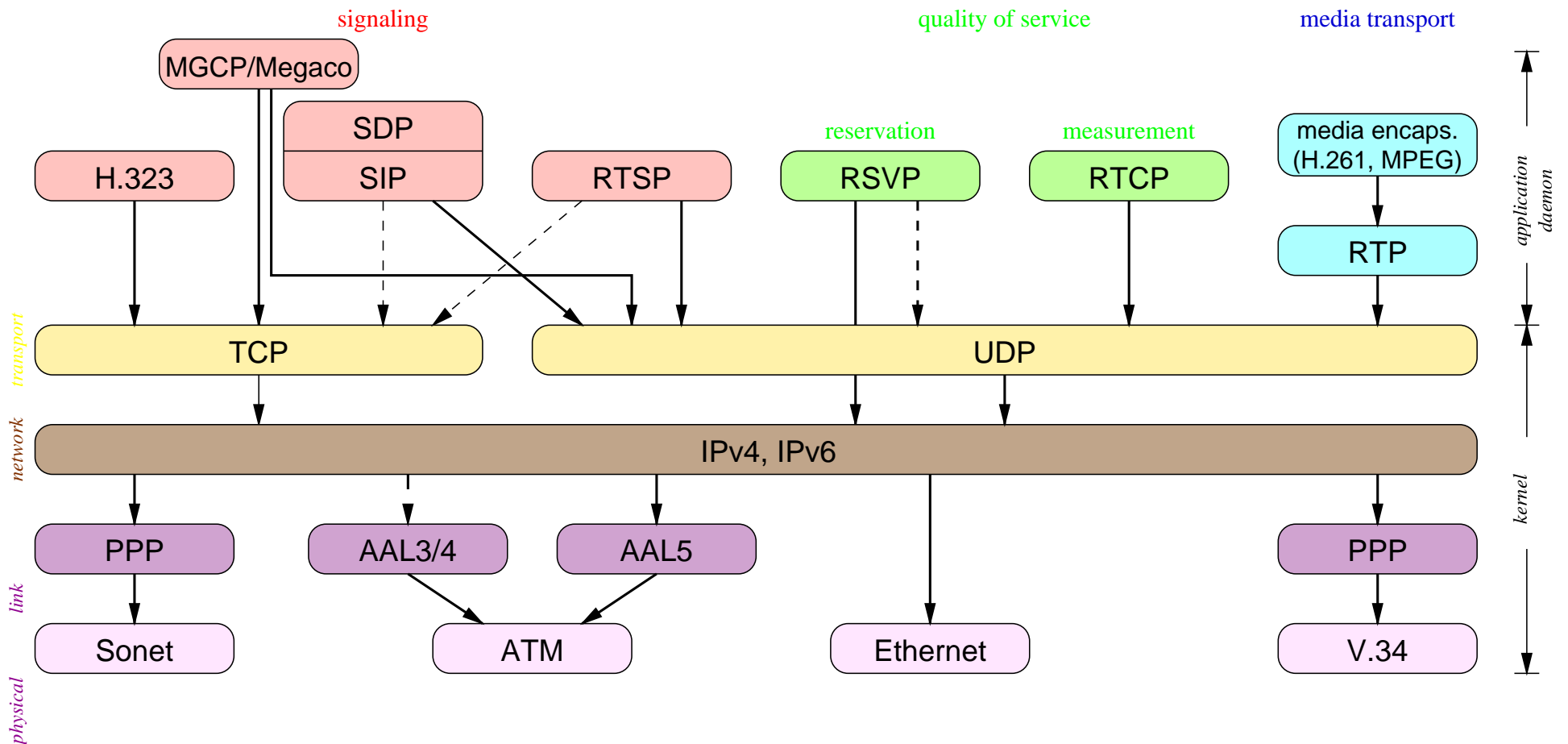

# Internet telephony modes

---

- tail-end hop off  $\Rightarrow$  callee has phone
- front-end hop on  $\Rightarrow$  caller uses phone
- Internet in the middle: per-call, multiplexed

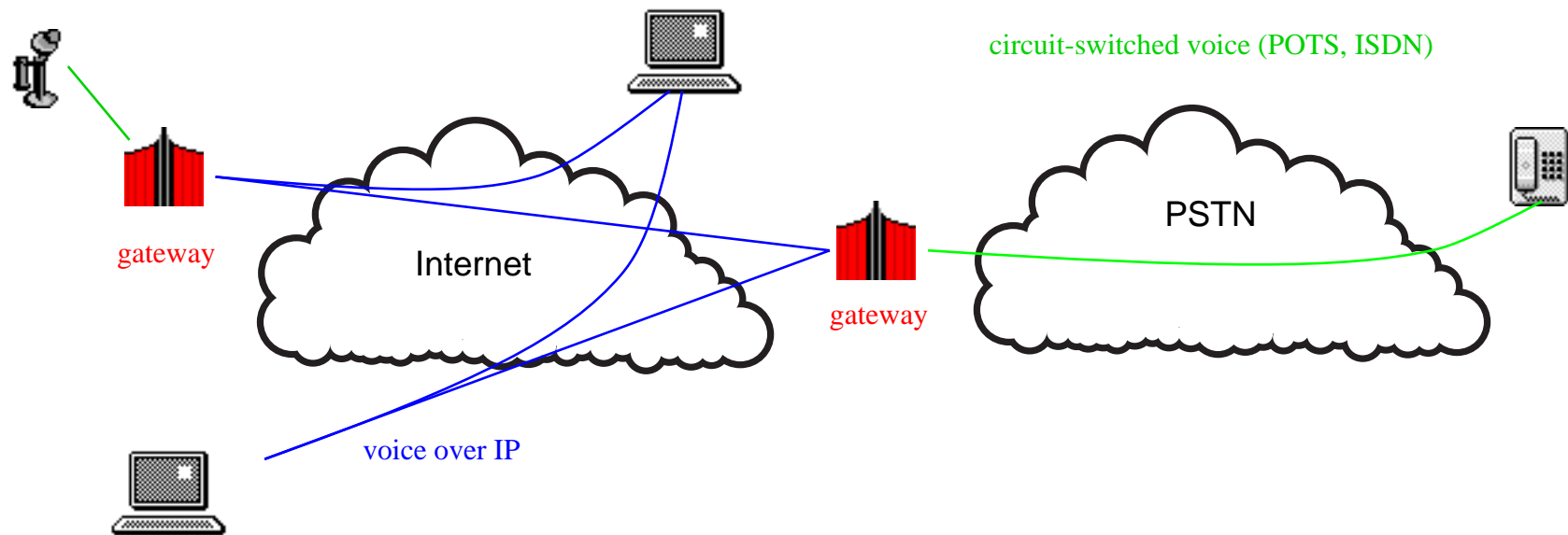

## Internet “signaling”

---

all non-data (“out-of-band”) functions:

**routing:** unicast; DVMRP, PIM, CBT for multicast ✓

**quality of service:** RSVP, RTCP, diff-serv ✓

**user Contact:** map name to location (IP address)

**call set-up/teardown:** SIP, H.323

**policy, billing:** “vertical” protocols

# Architecture

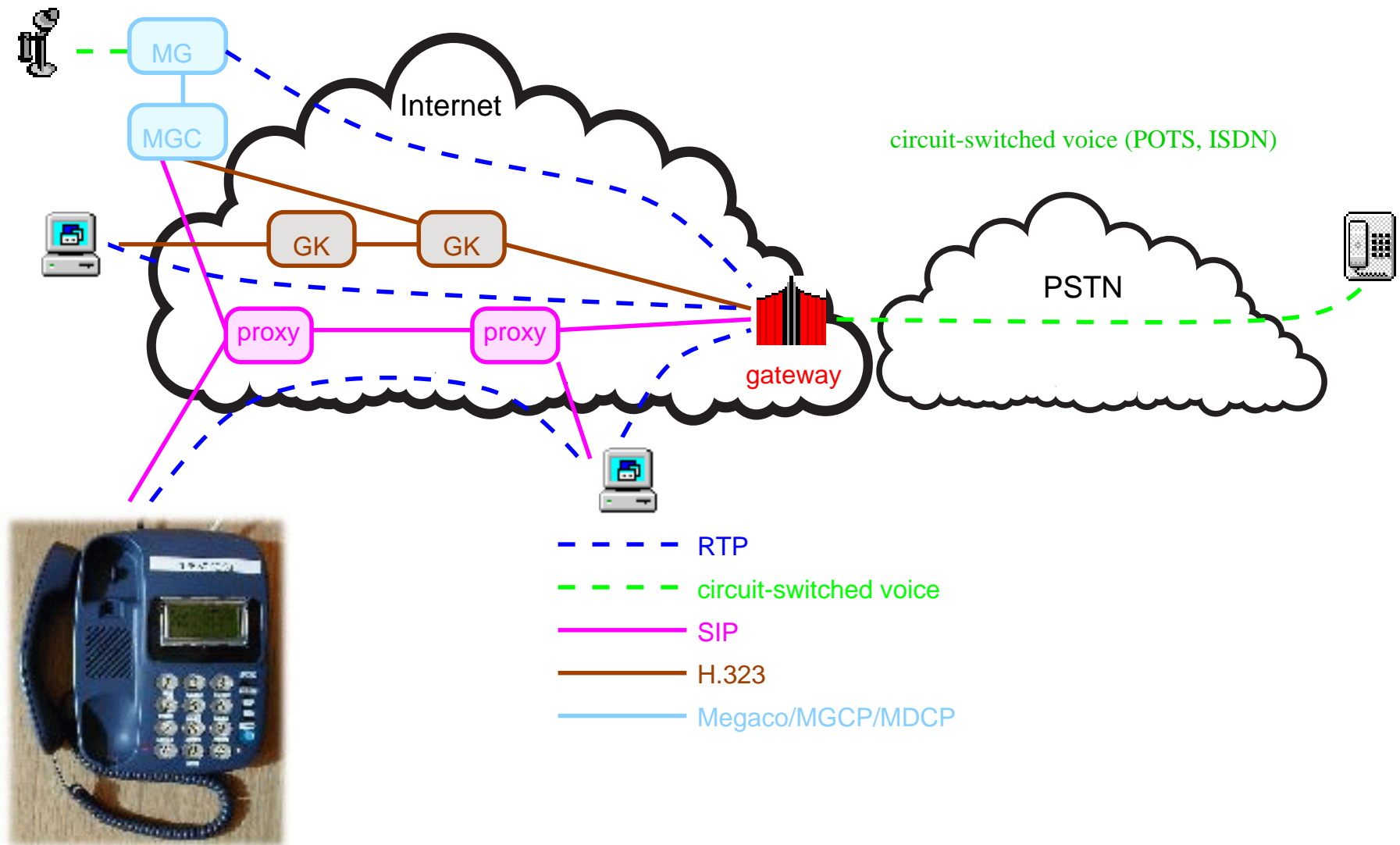

## Differences: Internet Telephony ↔ POTS

---

- separate control, transport (UDP) ⇒ no triangle routing
- separate connectivity from resource availability
- separate services from bit transport
- datagram service ⇒ less bootstrapping
- in-band signaling ⇒ higher speed
- features “network” → end system: distinctive ringing, caller id, speed dialing, number translation, ... ⇒ scaling
- features: intra-PBX = international
- protocols: user-network = network-network signaling

## Two Views of Internet Telephony

---

### Internet telephony:

- primarily voice
- look like phone system: ISDN signaling, separate “stack”
- interoperability with SS7
- or SS7 migration to Internet

### Internet telephony:

- VoIP = yet another Internet service
- voice = small fraction of traffic in ten years
- SS7 = legacy, to be relegated to edges
- integration with email, web
- multimedia, including non-CM

# Architecture

---

**Centrally controlled (master-slave):** media gateways controlled by call servers: “connect circuit 17 to IP address 128.59.19.1” → Megaco, MGCP

- all services in server control
- no need to modify end systems
- “pay \$4.59/month for call waiting, \$7.50 for caller id”

**Peer-to-peer:** equal participants, end-to-end

- services in proxy servers and end systems
- need to modify software for new services
- “download new software for \$19.95”

Connect MGCP islands using SS7 or peer-to-peer protocols



## Open Operational Issues

---

- reliability
- billing
- 911 (emergency) services
- wire tapping (CALEA)
- anonymity and certified identity

# Billing

---

- simplification: email/web delivery, credit card payment
- what to bill for?
  - transport services:** volume, time, reserved resources; “free upgrades”
  - signaling services:** filtering, forwarding, scripting, mobility, ...
  - storage services:** voice mail
  - gateway services:** PSTN gateways
- difficult: settlements between carriers – not simple LEC – IXC – LEC model

## Emergency (911) services

---

- U.S.: dial “911” anywhere → nearest Public Safety Answering Points
- look up street address from telephone company database
- but...
  - IP address dynamically assigned
  - may not be correlated to geography
  - dial-in from hotel, remote sites?
  - prevent services: hanging up, transfer, hold, ...

## Emergency services

---

- advantages:
  - multimedia (video, medical data, ...)
  - medical database access, with authentication token
  - remote activation of medical devices
- solutions:
  - enclose (signed) location information with call
  - IP address → provider → lookup (RADIUS) → needs authenticated protocol
  - GPS

## Lawful intercepts (“wiretapping”)

---

- Internet already has remote packet tapping: RMON, telnet + rtpdump, ...
- most intercepts done on local loop → Internet doesn't change that
- information services exempt from CALEA provisions
- difference between content and “pen register” (signaling) intercept
- see IETF raven mailing list

## Other issues

---

Lots more to talk about (but won't) ...

- carrying ISUP (SS7 signaling) over IP  $\Rightarrow$  SCTP
- using ISUP to set up IP bearers  $\Rightarrow$  BICC
- automatic configuration of IP phones
- (3G) wireless issues

## Summary

---

- transition of separate circuit-switched  $\Rightarrow$  IP-based applications
- VoIP: transport + QoS + signaling + services
- packets from the inside out or the outside in?
- Internet telephony OR Internet telephony
- stack: IP over ATM, Sonet, WDM?
- role of IPv6 or NATs?
- “the end of distance” or tiered IP service?