

SIP, Year 3: A Snapshot and Directions

Henning Schulzrinne
Dept. of Computer Science
Columbia University
New York, New York
(sip:)schulzrinne@cs.columbia.edu

Hewlett Packard, Bristol

April 24, 2001

Overview

- A brief history
- Status in early 2001
- Standardization status
- What's missing?
- New applications
- Potential roadblocks

IETF VoIP Protocol Architecture

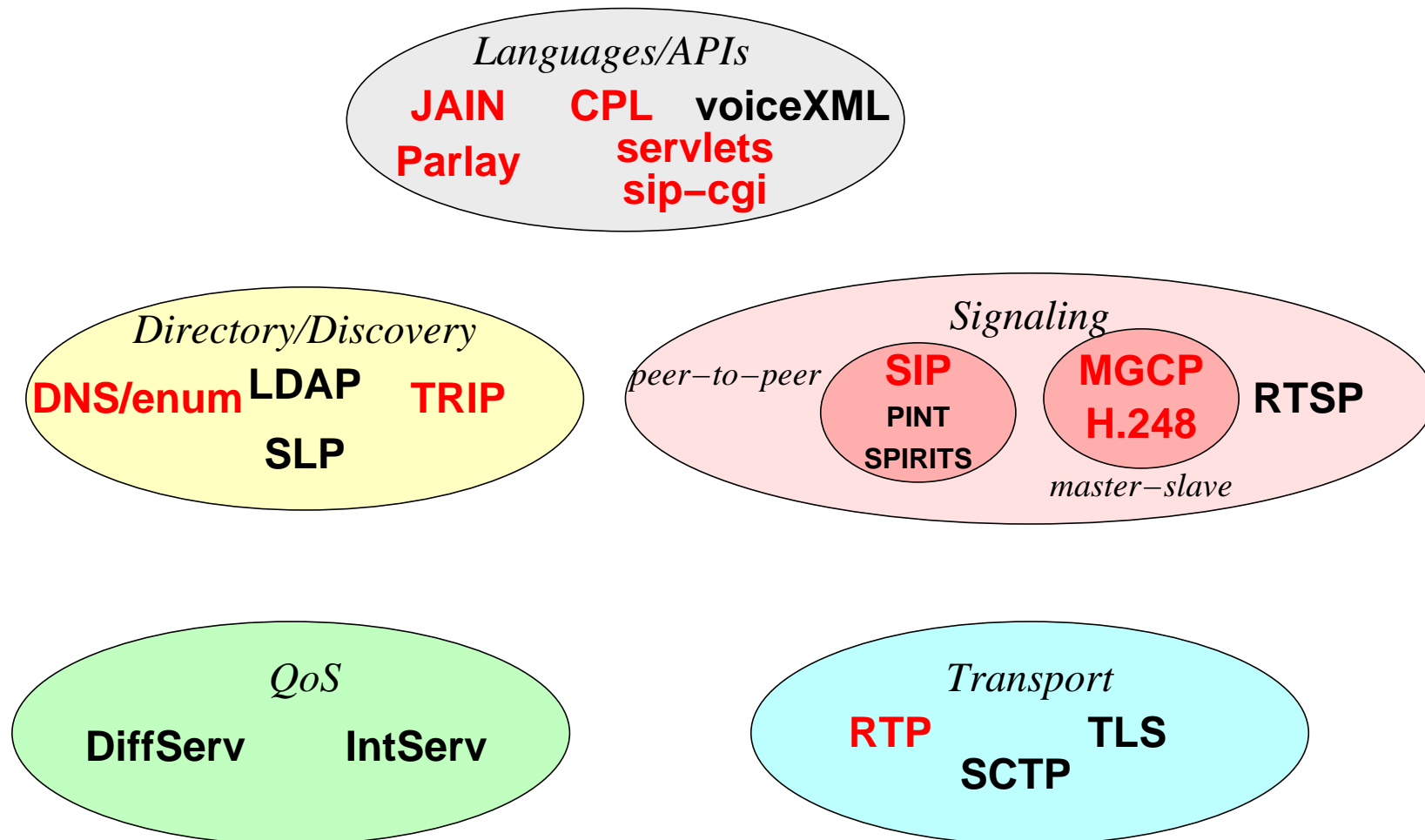

Whence SIP?

Feb. 1996: earliest Internet drafts

Feb. 1999: *Proposed Standard*

March 1999: RFC 2543

April 1999: first SIP bake-off

November 2000: SIP accepted as 3GPP signaling protocol

December 2001: 6th bake-off, 200+ participants

March 2001: 7th bake-off, first time outside U.S.

SIP years

Year	development	trade rags
1996-1998	R&D	“academic exercise”, “distraction from H.323”
1999	standard & skunk works	“what does SIP stand for again?”
2000	product development	“SIP cures common cold!”
2001	pioneer deployment	“Where are the SIP URLs?”
2002	kmart.com/sip	SIP product comparisons

SIP Status Early 2001

- almost all telecom equipment vendors working on SIP products
- first general-availability SIP hardware (Ethernet phones, small gateways), but limited
- number of SIP proxy servers in customer trials
- ready for field trials and early-adopter “PBX-free” enterprises
- but can't buy couple of SIP phones from web page

So I Want to Build a SIP Network...

Ready for trials, but probably not quite for shrink-wrap status:

- installation and operation still requires fair amount of expertise
- lots of web and email experts, few SIP experts
- needs some external infrastructure: DHCP and SRV, possibly AAA
- inconsistent configuration for Ethernet phones (being worked on)
- SIP phones still more expensive than analog phones \Rightarrow hard to justify PBX replacement (incremental cost)
- no just-download or ship-with-OS “soft” clients

Need for Services

- need carriers that offer SIP gateways
- without having to provide SS7 connectivity
- with outbound PSTN calling
- with inbound calls and *number portability* – need to be able to keep old PSTN numbers
- either IP Centrex model or in-house servers – like ISP services for email or web
- for commercial-grade conferences, need nailed-up Internet connectivity, orderable (at least) by web page – across providers!
- PBX revenue already decreasing

Why aren't we junking switches right now?

What made other services successful?

email: available within self-contained community (CS, EE)

web: initially used for local information

IM: instantly available for all of AOL

All of these ...

- work with bare-bones connectivity (≥ 14.4 kb/s)
- had few problems with firewalls and NATs
- don't require a reliable network

Why aren't we junking switches right now?

Telephone services are different:

- reliability expectation 99.9% ↗ 99.999%
- PC not well suited for making/receiving calls – most residential handsets are cordless or mobile
- business sets: price incentive minor for non-800 businesses
- services, multimedia limited by PSTN interconnection
- initial incentive of access charge bypass fading (0.5c/min.)
- international calls only outside Western Europe and U.S.

Prognosis

- much less cable telephony than predicted, mostly boring GR303
- greenfield PBX installations for net-savvy enterprises
- enhancements for maxed-out PBXs – need PBX Ethernet interfaces
- tie-line replacements for branch offices
- backbones for some carriers
- maybe DSL and cable modems, but lifeline? replacement of cordless phones?
- 3G deployment, assuming any 3G companies not bankrupted by license fees

Prognosis, cont'd.

- BICC & ISUP-carriage for legacy-burdened carriers
- H.323 for conferencing (until Microsoft ships Windows SIP client ...)
- need T.120-equivalent for cross-platform screen sharing, e.g., VNC

Standardization

- SIP working group is one of the most active in IETF
- located in “transport” area, but really an application
- about 80 active Internet drafts related to SIP
- typically, 400 attend WG meetings at IETF
- but few drafts are working group items
- 80-20% – 80% of the technical work takes 20% of the time

Standards process

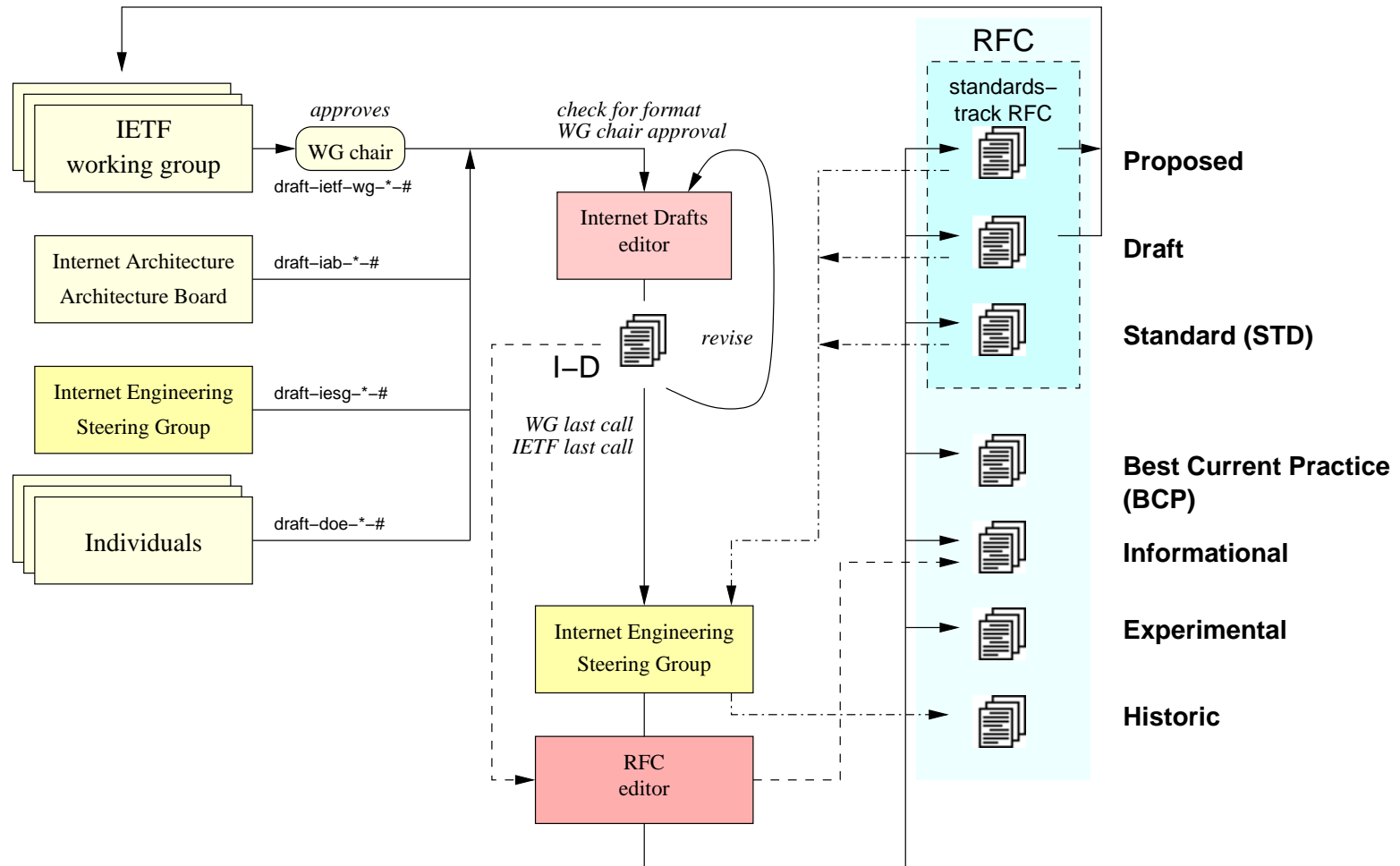

IETF growth: meeting attendance

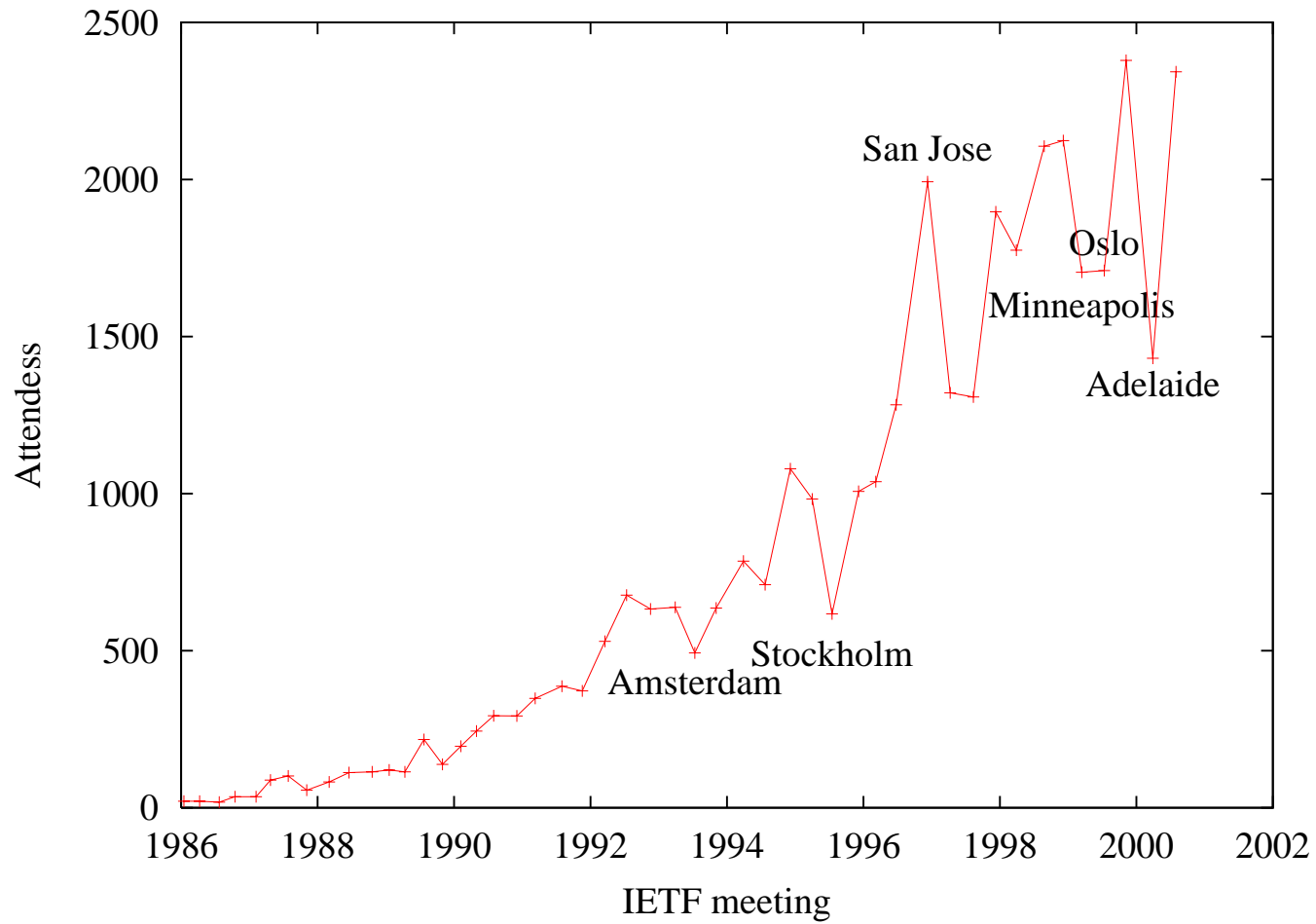

IETF is getting slower

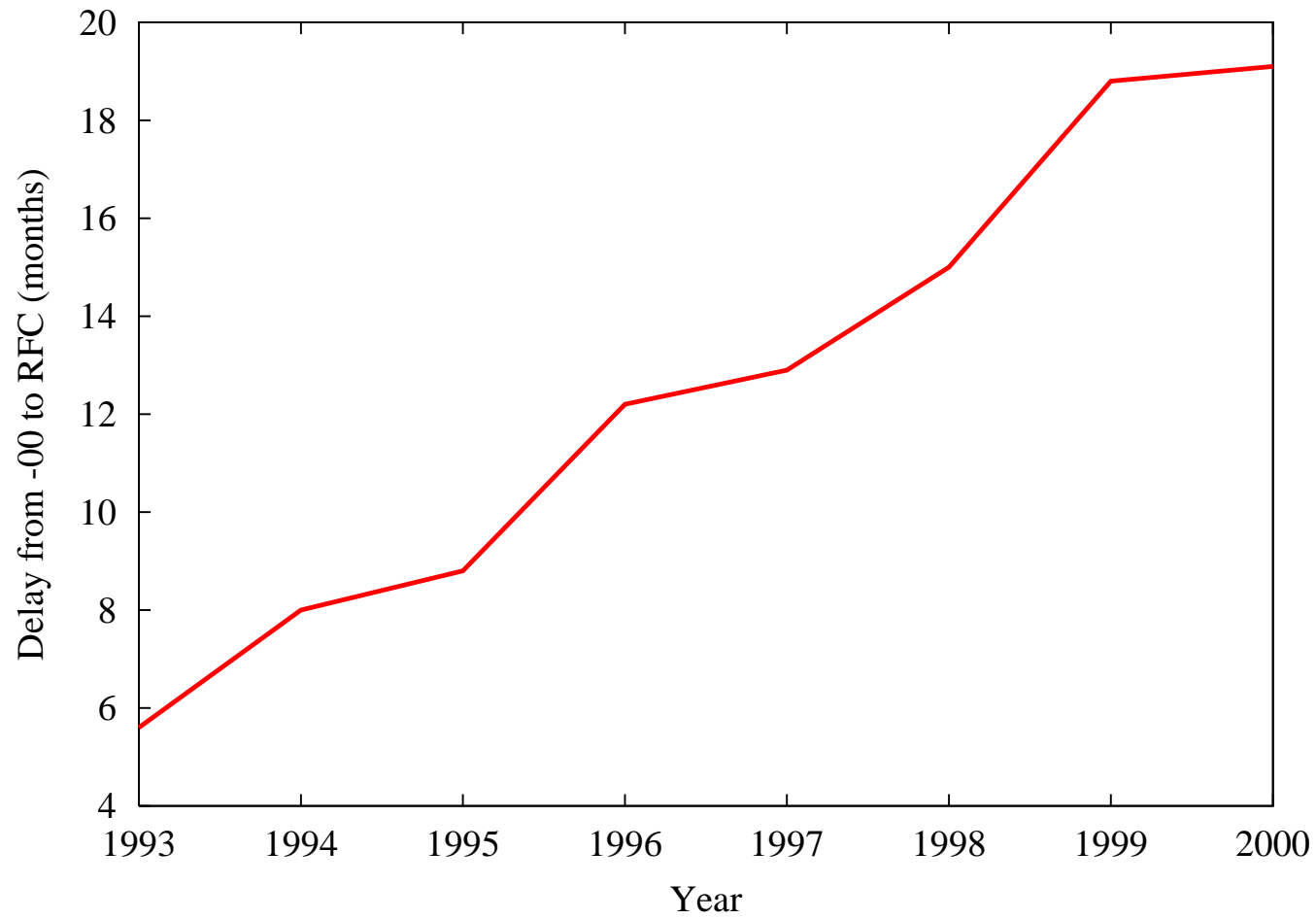

SIP progress

- revision of RFC 2543 (“rfc2543bis”) in progress
- **There will be no SIP/3.0**
- all changes are backwards-compatible or pick one interpretation of RFC 2543
- more major changes:
 - removal of Via hiding
 - Record-Route for backward direction
 - possibly removal of PGP, replacement by S/MIME
 - few additional status codes
 - informational headers, e.g., Reply-To, Alert-Info, Call-Info

Status of SIP working group items

reliable provisional	IESG review
caller preferences	WG last call done
call flows	ready for last call
SIP guidelines	WG last call done
ISUP over MIME	ready for IESG
SIP MIB	needs update
server feature ann.	revisions based on IESG feedback
service examples	needs work
session timer	ready for WG last call
call transfer	in revision
state maintenance	ready for last call
DHCP	IESG revisions done

Standardization

- interaction with resource reservation
- caller preferences (“no mobile phones, please”)
- interoperation with ISUP (“SIP-T”)
- call transfer and third-party control
- conferencing: central server, end system, full mesh
- server benchmarking and scaling
- requirements for deaf users
- call processing language: coordination with iCal

PSTN legacies to avoid

- E.164 numbers – might as well wear bar codes
 - tones and announcements
 - in-band signaling for features (DTMF)
 - systems with user-interface knowledge (12 keys, voice)
 - voice-only orientation (BICC, MGCP/Megaco)
 - integration of bit transport and services
 - service-specific billing ▮▮▮▮▶ separate signaling & billing
 - trusted networks without crypto
- ▮▮▮▮▶ confine PSTN knowledge to edge of network

Invisible Internet telephony

“VoIP” technology will appear in

- Internet appliances
- home security cameras, web cams
- 3G mobile terminals
- fire alarms and building sensors
- chat/IM tools
- interactive multiplayer games
- 3D worlds: proximity triggers call

Internet Telephony – as Part of Internet

- universal identifier: email address = SIP address = IM address
- SIP URLs in web pages
- forward to email, web page, chat session, ...
- include web page in invitation response (“web IVR”)
- third-party control of calls via scripts,
- include vCard, photo URL in invitation
- user-programmable services: CGI (RFC 3050), CPL, servlets

Example: Columbia CS phone system

Expand existing PBX via IP phones, with transparent connectivity

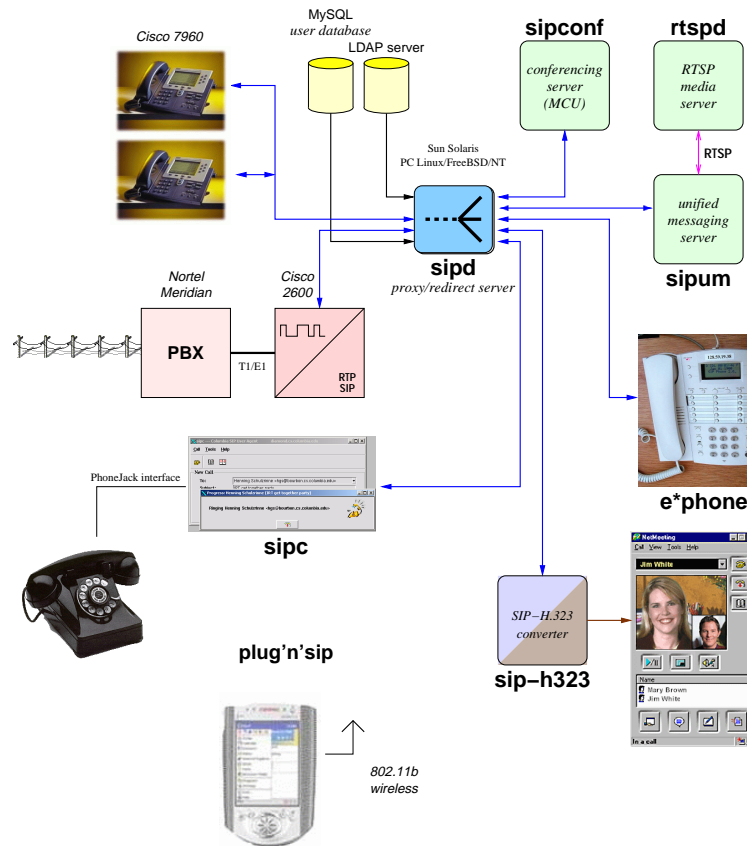

The largest signaling network does not run SS7

- AT&T: 280 million calls a day
- AOL: 110 million emails/day, total about 18 billion/day
- total > 1 billion instant messages/day (AOL: 500 million)
- telephony signaling \approx IM, presence

Events as universal glue

- currently, don't have general event notification in the Internet
- email is too slow: pull on the last hop (server to user)
- generic problem:
 - “voicemail has arrived”
 - “called party is reachable”
 - “new configuration data available”
 - “IR sensor has detected movement”
 - “boiler temperature above threshold”
 - ...
- same delivery (SIP), different data (XML DTDs)

Commonalities between signaling and events

- presence is just a special case of an event: “Alice logged in” \approx “house temperature dropped below 50 deg.”
- need to locate mobile end points (for notifications)
- may need to find several different destinations
- same addressing for users
- presence often precursor to calls
- may replace call back and call waiting
- likely to be found in same devices
- events already in VoIP: message alert, call events, conf. joins

SIP as a presence & event platform

- minimal SIP extension: **SUBSCRIBE** to request notifications, **NOTIFY** when event occurs
- also, **MESSAGE** for IM, sessions for multi-party chats
- transition to true “chat” (and video)
- services such as reaching mobile phone while in meeting

Events: SIP for appliances

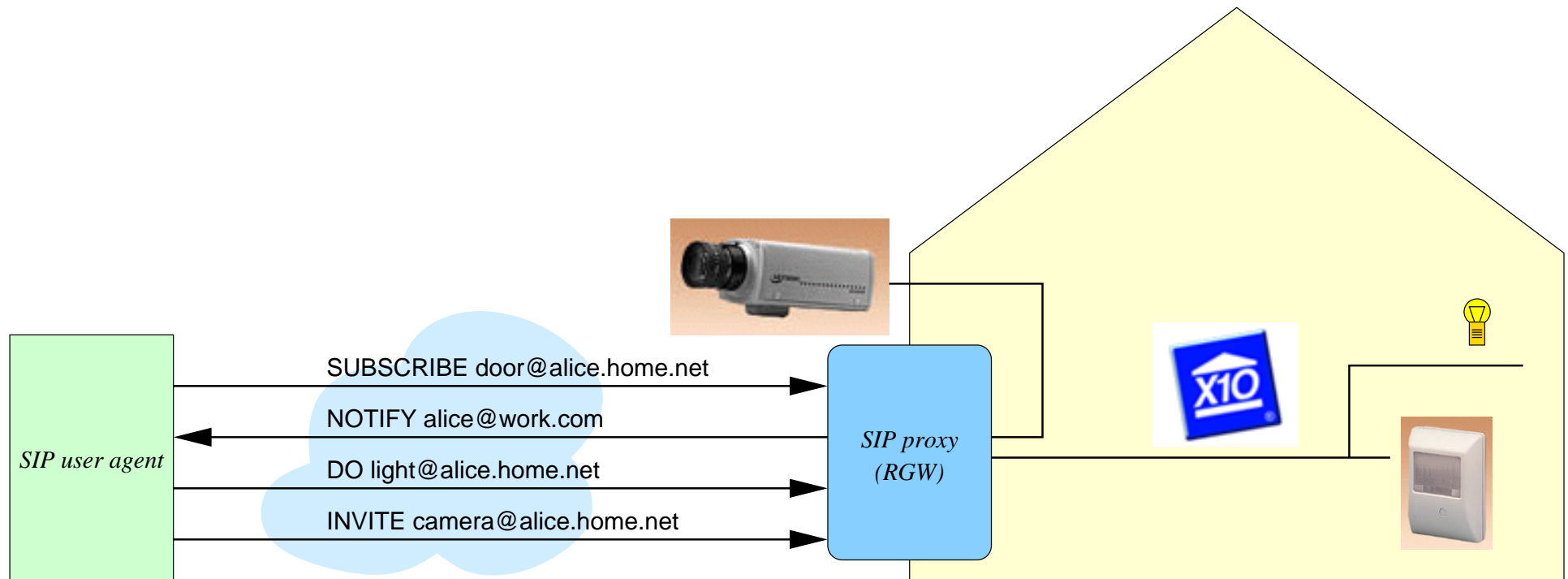

Challenges and obstacles

- scalable device configuration
- PSTNv3
- “walled garden”
- service infrastructure
- standardization
- invisible Internet telephony

Potential obstacles

- SIP as transport – for legacy signaling
 - due to proxies, UDP not designed for volume data
 - doesn't add significant value
- NATs and firewalls – can engineer around them, but ugly
 - leads to IP-over-HTTP solutions, defeating firewall
 - proxy boxes outside NATs

Device configuration

- need to plug in store-bought phone, without more than personalization
- limited user interface
- configuration from local (visited) network and from home network
- don't want current PBX single-vendor tie-ins
- cannot rely on California-style upgrades
- notifications of new configurations **▣▣▣▣➔ SUBSCRIBE/NOTIFY**

Device configuration

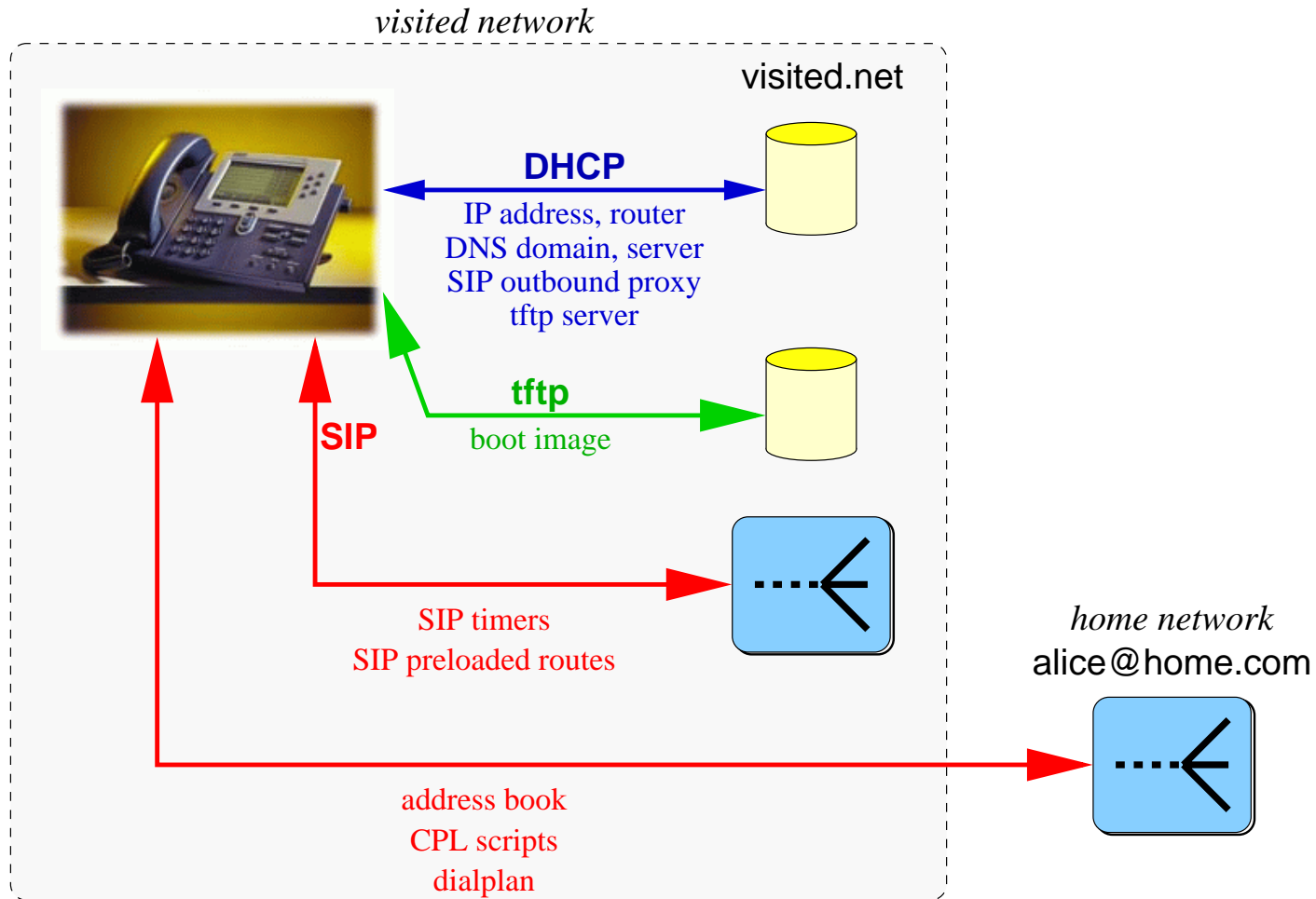

Programming Internet multimedia services

Primarily, creation, forwarding, proxying, rejection of calls

APIs (Parlay, JAIN): protocol-neutral (SIP, H.323, ISUP), but may be least common denominator

SIP CGI: use Perl and other scripting languages; easy to learn

Servlets: Java only; faster than cgi; limited functionality

CPL: = XML-based language for *user* service creation; portable across providers, but not all services

- Protocol-neutral: Parlay, JAIN, CPL
- Call creation: Parlay, JAIN
- VoiceXML is for voice-service creation *after* call setup

Conclusion

- basic IETF-based architecture in place
- SIP as foundation for services
- extensions for mobility, emergency services, ... in progress
- first (and last?) chance to recover from 120 years of legacy
- avoid replication of PSTN on packets
- most VoIP applications won't look like telephones
- range of engagement and asynchronicity, from call to IM to email
- challenge of mobile services

For more information...

SIP: <http://www.cs.columbia.edu/sip>

RTP: <http://www.cs.columbia.edu/~hgs/rtp>

Papers: <http://www.cs.columbia.edu/IRT>