

HW #8

ELEN E4710 - Intro to Network Engineering
Spring 2002

Due 5/2/2002
Prof. Rubenstein

Homework must be turned in at the beginning of class on the due date indicated above. CVN students have one additional day. Late assignments will not be accepted.

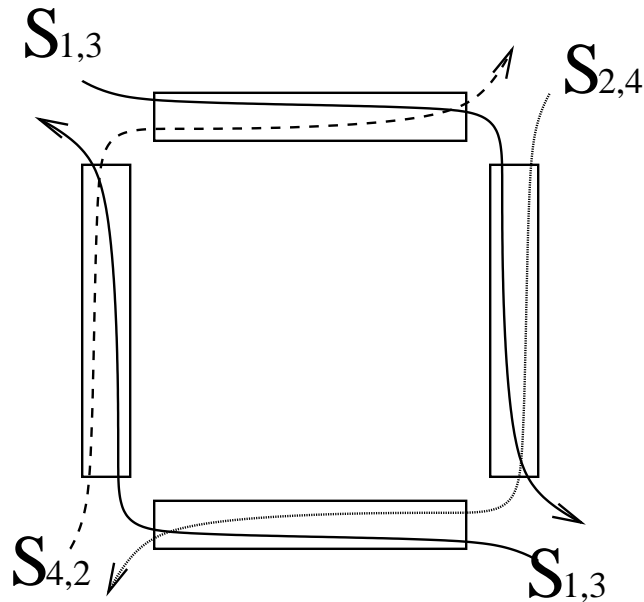

1. Consider the network pictured above where each link has capacity C , each session transmits into the network at rate ρ , and each session's transmissions traverse two links. In class, we showed how increasing the flow rate beyond $C/2$ led to congestion collapse. How can priority queuing be used to prevent collapse where the priority mechanism does not know the capacity of the link (i.e., you cannot simply restrict the entry rate of the flow into the link to $C/2$)? (Hint: How should each link prioritize the session data that it carries so that flow is not "wasted" by passing through the first link and then being dropped at the second?)
2. A flow will traverse a set of routers R_1, \dots, R_n where router R_i will process its packets at (deterministic) rate λ_i and can queue up to b_i packets at a time without dropping any.
 - (a) Assuming the flow has reserved access to the router resources (such that no other flow competes for the resources described above), what is the leaky bucket configuration (ρ, b) that the flow should use (where ρ is the rate at which tokens enter the bucket and b is the maximum number of tokens the bucket can hold) to maximize the transmission rate such that a packet is never lost?
 - (b) Give an example of transmission sequence that leads to a packet loss when the leaky bucket is configured using (ρ', b') , where $\rho' = \rho$ and $b' > b$.
 - (c) Give an example of transmission sequence that leads to a packet loss when the leaky bucket is configured using (ρ', b') , where $\rho' > \rho$ and $b' = b$.

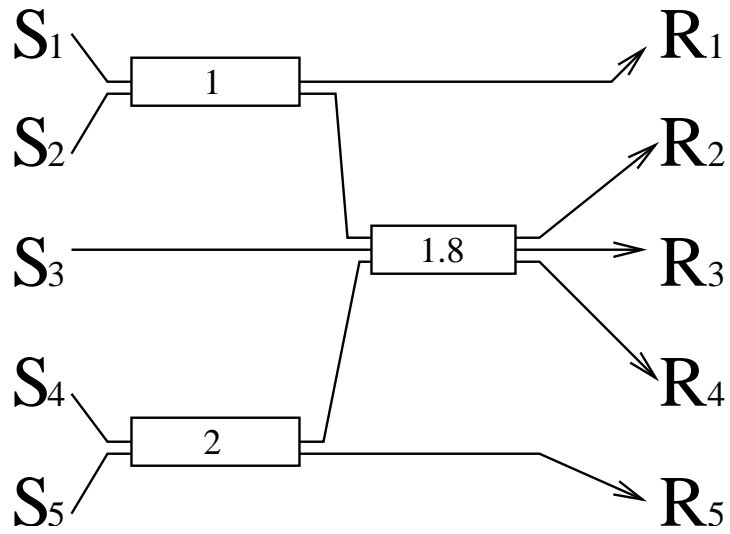

3. Consider the network shown above.

- Explain why an allocation of rates 0.4, 0.6, 0.6, 0.6, 1.4 respectively to flows 1,2,3,4,5 is not max-min fair.
- Explain why an allocation of rates 0.5, 0.5, 0.3, 1, 1 respectively to flows 1,2,3,4,5 is not max-min fair.
- What is the max-min fair allocation for the depicted network?