

Joint Sentence Extraction and Fact Checking with Pointer Networks



Chris Hidey^{1,2} and Mona Diab²
1-Columbia University 2-Amazon AWS AI Lab



Approach

1. Use lexical model to extract top K articles and top N sentences
2. Multi-task learning for predicting labels and ranking sentences

Entities vs Inference

Claim: Drake Bell put out an EP.

Jared Drake Bell

(born June 27, 1986)

is an American actor, voice actor, and musician.



Born in Newport Beach, California, he began his career as an actor in the early 1990s at the age of five with his first televised appearance on Home Improvement. Bell also appeared in several commercials, such as one for Pokémon Red and Blue, but is best known for his starring roles on Nickelodeon's The Amanda Show and Drake & Josh. Bell starred in a trilogy of The Fairly OddParents movies on Nickelodeon.

Bell was the voice of Peter Parker / Spider-Man in the animated series Ultimate Spider-Man on Disney XD.

Bell released an EP in 2011 called A Reminder independently.

Document

- DrQATF/IDF for full article
- Noun phrase overlap between 1st & 2nd sentences in Wikipedia
- Average, maximum, minimum of GloVe embeddings in *claim* and 1st and 2nd sentences
- *Claim* and title overlap

Doc. Retrieval Results

Method	Recall at k=5	
	Dev.	Test
DrQA	55.3	54.2
Title Features	82.7	79.7
Full	90.7	90.5

Evidence Selection and Relation Prediction

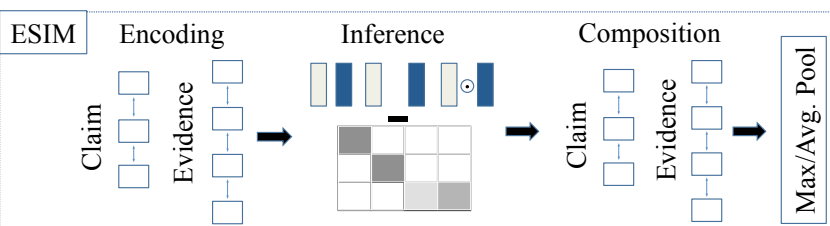
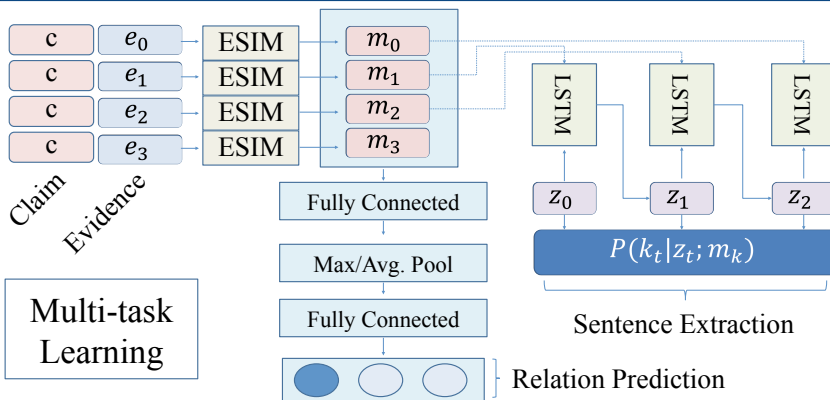

Extraction and Relation Prediction Results

Method	Development			Test		
	Accuracy	Recall	FEVER	Accuracy	Recall	FEVER
Baseline	52.1	44.2	32.6	50.9	45.9	31.9
Full	64.5	79.6	55.3	61.9	77.7	53.2
Pointer MLP	60.4	76.6	51.1	58.7	74.0	49.1
ESIM LSTM	55.9	59.8	38.4	53.3	54.5	34.7
-MTL	56.8	74.9	45.3	53.8	72.7	42.3
+Gold Doc.	68.5	96.0	66.2	65.4	95.2	62.8

Error Analysis

Evidence Required	Number of Examples	Percent of Verifiable	Accuracy	Sentence Recall	Document Recall
0	3333	N/A	50.0	N/A	N/A
1	6043	90.7	72.4	86.2	93.5
2	542	8.1	65.3	17.2	29.3
3+	81	1.2	71.6	2.5	16.0

- Joint training significantly improves relation prediction
- Document retrieval is difficult, especially when evidence > 1
- Not enough info is challenging given limited context