

Artificial Intelligence

Intelligent Agents



Ansaf Salleb-Aouissi

Agents and environments

- **Agent:** An **agent** is anything that can be viewed as:
 - **perceiving** its **environment** through **sensors** and
 - **acting** upon that **environment** through **actuators**.

Agents and environments

- **Agent:** An **agent** is anything that can be viewed as:
 - **perceiving** its **environment** through **sensors** and
 - **acting** upon that **environment** through **actuators**.

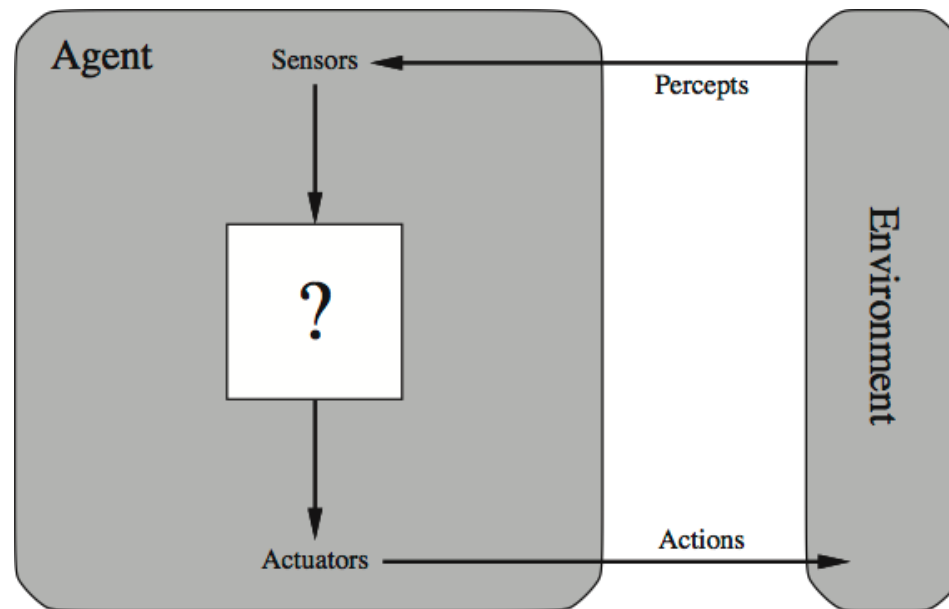

- An agent program runs in cycles of: (1)perceive, (2)think, and (3)act.

Agents and environments

- **Agent:** An **agent** is anything that can be viewed as:
 - **perceiving** its **environment** through **sensors** and
 - **acting** upon that **environment** through **actuators**.

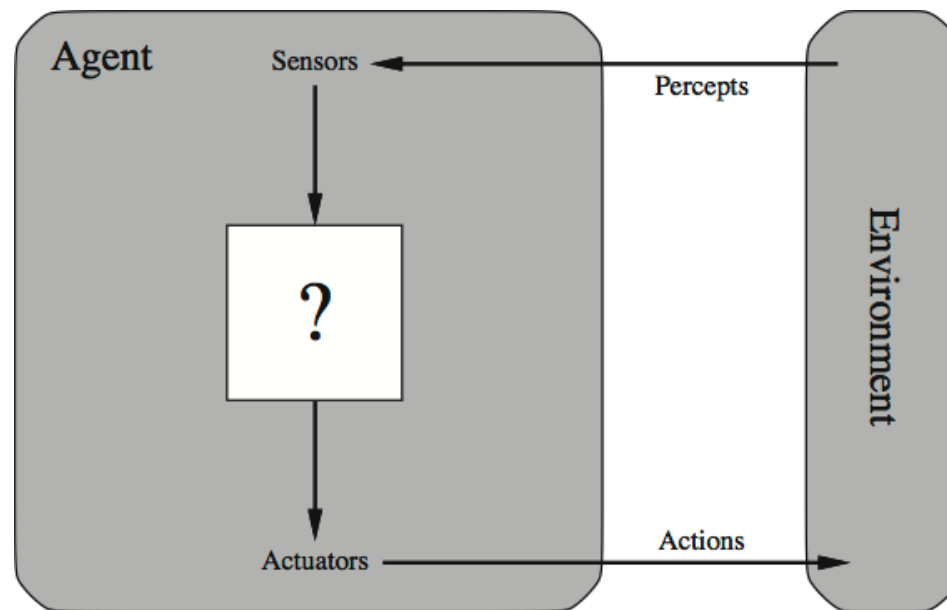

- An agent program runs in cycles of: (1)perceive, (2)think, and (3)act.
- **Agent = Architecture + Program**

Agents and environments

- **Human agent:**
 - Sensors: eyes, ears, and other organs.
 - Actuators: hands, legs, mouth, and other body parts.
- **Robotic agent:**
 - Sensors: Cameras and infrared range finders.
 - Actuators: Various motors.

Agents and environments

- **Human agent:**
 - Sensors: eyes, ears, and other organs.
 - Actuators: hands, legs, mouth, and other body parts.
- **Robotic agent:**
 - Sensors: Cameras and infrared range finders.
 - Actuators: Various motors.
- **Agents everywhere!**
 - Thermostat
 - Cell phone
 - Vacuum cleaner
 - Robot
 - Alexa Echo
 - Self-driving car
 - Human
 - etc.

Vacuum cleaner

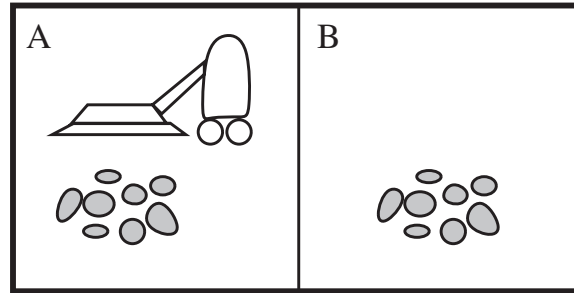

- Percepts: location and contents e.g., [A, Dirty]
- Actions: Left, Right, Suck, NoOp
- Agent function: mapping from percepts to actions.

Vacuum cleaner

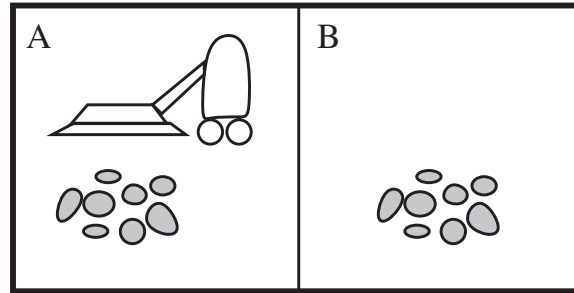

- Percepts: location and contents e.g., [A, Dirty]
- Actions: Left, Right, Suck, NoOp
- Agent function: mapping from percepts to actions.

Percept	Action
[A, clean]	Right
[A, dirty]	Suck
[B, clean]	Left
[B, dirty]	Suck

Well-behaved agents

Rational Agent:

*“For each possible percept sequence, a rational agent should select an action that is expected to maximize its **performance measure**, given the evidence provided by the percept sequence and whatever built-in knowledge the agent has.”*

Rationality

- Rationality is relative to a **performance measure**.
- Judge rationality based on:
 - The performance measure that defines the criterion of success.
 - The agent prior knowledge of the environment.
 - The possible actions that the agent can perform.
 - The agent's percept sequence to date.

PEAS

- When we define a rational agent, we group these properties under **PEAS**, the problem specification for the task environment.
- The rational agent we want to design for this task environment is the solution.
- PEAS stands for:
 - **P**erformance
 - **E**nvironment
 - **A**ctuators
 - **S**ensors

PEAS

What is PEAS for a self-driving car?



- **P**erformance:
- **E**nvironment:
- **A**ctuators:
- **S**ensors:

PEAS

What is PEAS for a self-driving car?



- **P**erformance: Safety, time, legal drive, comfort.
- **E**nvironment:
- **A**ctuators:
- **S**ensors:

PEAS

What is PEAS for a self-driving car?



- **P**erformance: Safety, time, legal drive, comfort.
- **E**nvironment: Roads, other cars, pedestrians, road signs.
- **A**ctuators:
- **S**ensors:

PEAS

What is PEAS for a self-driving car?



- **P**erformance: Safety, time, legal drive, comfort.
- **E**nvironment: Roads, other cars, pedestrians, road signs.
- **A**ctuators: Steering, accelerator, brake, signal, horn.
- **S**ensors:

PEAS

What is PEAS for a self-driving car?



- **P**erformance: Safety, time, legal drive, comfort.
- **E**nvironment: Roads, other cars, pedestrians, road signs.
- **A**ctuators: Steering, accelerator, brake, signal, horn.
- **S**ensors: Camera, sonar, GPS, Speedometer, odometer, accelerometer, engine sensors, keyboard.

PEAS

How about a vacuum cleaner?

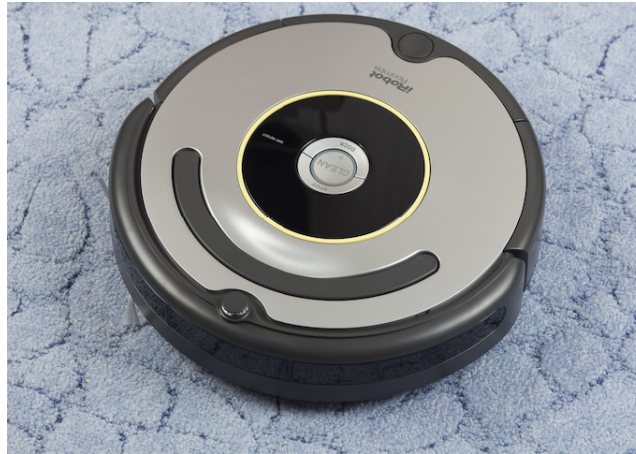

iRobot Roomba series

PEAS

How about a vacuum cleaner?

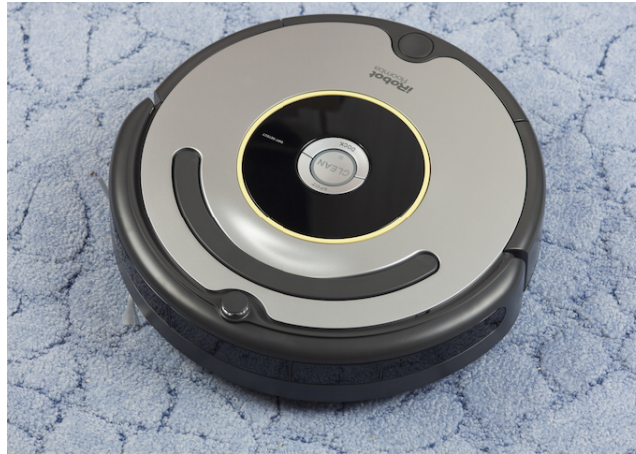

iRobot Roomba series

- **P**erformance: cleanness, efficiency: distance traveled to clean, battery life, security.
- **E**nvironment:
- **A**ctuators:
- **S**ensors:

PEAS

How about a vacuum cleaner?

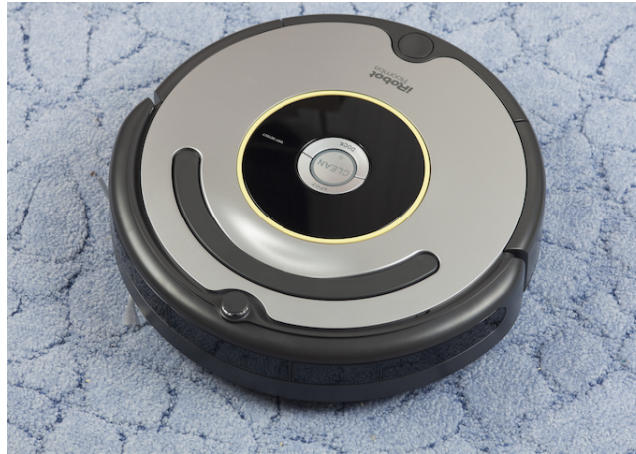

iRobot Roomba series

- **P**erformance: cleanness, efficiency: distance traveled to clean, battery life, security.
- **E**nvironment: room, table, wood floor, carpet, different obstacles.
- **A**ctuators:
- **S**ensors:

PEAS

How about a vacuum cleaner?

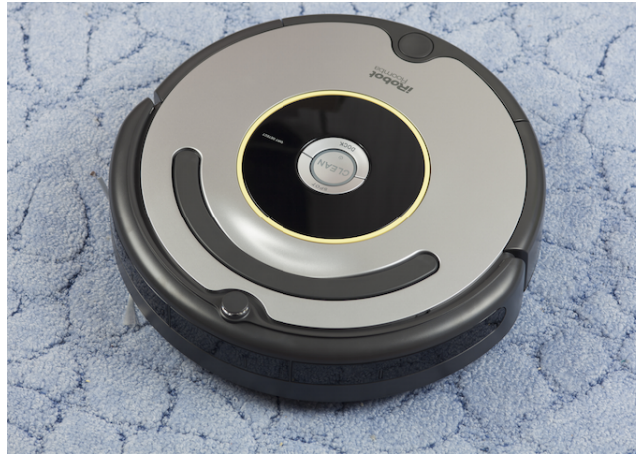

iRobot Roomba series

- **P**erformance: cleanness, efficiency: distance traveled to clean, battery life, security.
- **E**nvironment: room, table, wood floor, carpet, different obstacles.
- **A**ctuators: wheels, different brushes, vacuum extractor.
- **S**ensors:

PEAS

How about a vacuum cleaner?

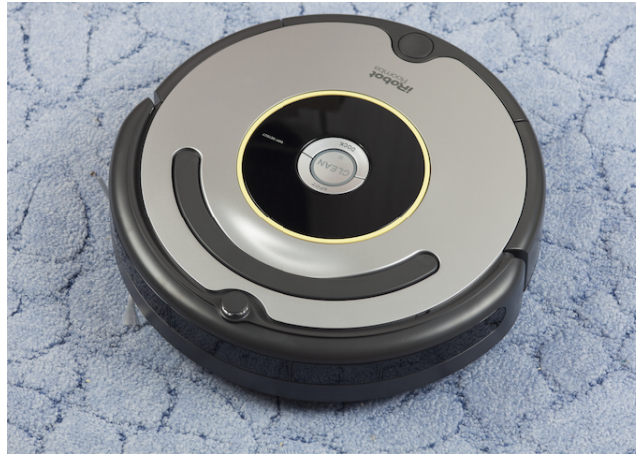

iRobot Roomba series

- **P**erformance: cleanness, efficiency: distance traveled to clean, battery life, security.
- **E**nvironment: room, table, wood floor, carpet, different obstacles.
- **A**ctuators: wheels, different brushes, vacuum extractor.
- **S**ensors: camera, dirt detection sensor, cliff sensor, bump sensors, infrared wall sensors.

Environment types

- **Fully observable (vs. partially observable):** An agent's sensors give it access to the complete state of the environment at each point in time.
- **Deterministic (vs. stochastic):** The next state of the environment is completely determined by the current state and the action executed by the agent. (If the environment is deterministic except for the actions of other agents, then the environment is strategic). In stochastic environments, uncertainty about outcomes is modeled with probabilities.
- **Static (vs. dynamic):** The environment is unchanged while an agent is deliberating. (The environment is semi-dynamic if the environment itself does not change with the passage of time but the agent's performance score does.)

Environment types

- **Discrete (vs. continuous):** A limited number of distinct, clearly defined percepts and actions. E.g., checkers is an example of a discrete environment, while self-driving car evolves in a continuous one.
- **Single agent (vs. multi-agent):** An agent operating by itself in an environment.
- **Known (vs. Unknown):** The designer of the agent may or may not have knowledge about the environment makeup. If the environment is unknown the agent will need to know how it works in order to decide.

Environment types

Environment	Observable	Agents	Deterministic	Static	Discrete
8-puzzle					
Chess					
Pocker					
Backgammon					
Car					
Roomba					

Environment types

Environment	Observable	Agents	Deterministic	Static	Discrete
8-puzzle	Fully	Single	Deterministic	Static	Discrete
Chess	Fully	Multi	Deterministic	(Semi)Static	Discrete
Pocker	Partially	Multi	Stochastic	Static	Discrete
Backgammon	Fully	Multi	Stochastic	Static	Discrete
Car	Partially	Multi	Stochastic	Dynamic	Continuous
Roomba	Partially	Single	Stochastic	Dynamic	Continuous

Agent types

- Four basic types in order of increasing generality:
 - Simple reflex agents
 - Model-based reflex agents
 - Goal-based agents
 - Utility-based agents
- All of which can be generalized into learning agents that can improve their performance and generate better actions.

Simple reflex agents

- Simple reflex agents select an action **based on the current state only** ignoring the percept history.
- Simple but limited.
- Can only work if the environment is **fully observable**, that is the correct action is based on the **current** percept only.

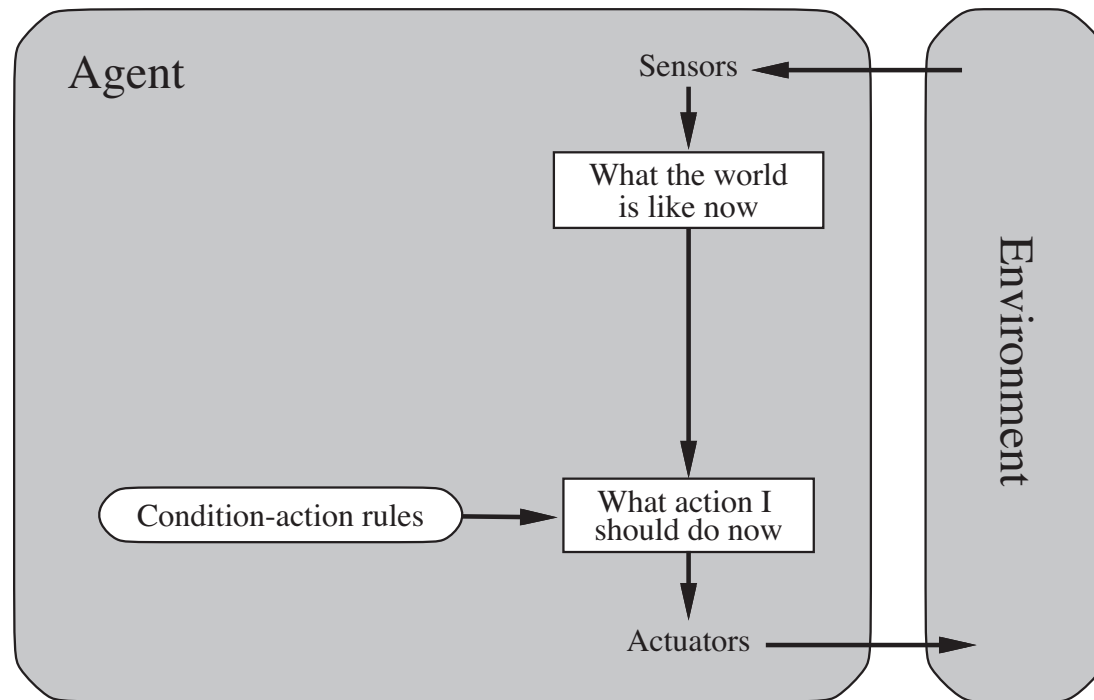

Vacuum (reflex) agent

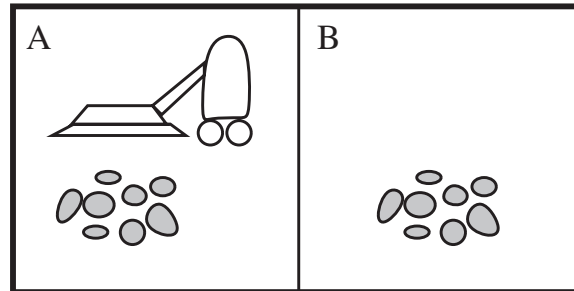

- Let's write the algorithm for the Vacuum cleaner...
- Percepts: location and content (location sensor, dirt sensor).
- Actions: Left, Right, Suck, NoOp

Percept	Action
[A, clean]	Right
[A, dirty]	Suck
[B, clean]	Left
[B, dirty]	Suck

Vacuum (reflex) agent

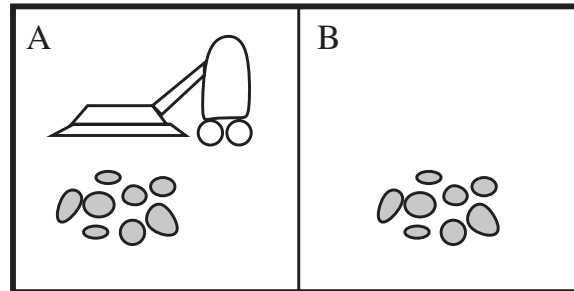

- Let's write the algorithm for the Vacuum cleaner...
- Percepts: location and content (location sensor, dirt sensor).
- Actions: Left, Right, Suck, NoOp

Percept	Action
[A, clean]	Right
[A, dirty]	Suck
[B, clean]	Left
[B, dirty]	Suck

What if the vacuum agent is deprived from its location sensor?

Model-based reflex agents

- Handle **partial observability** by keeping track of the part of the world it can't see now.
- Internal state depending on the percept history (**best guess**).
- Model of the world based on (1) how the world evolves independently from the agent, and (2) how the agent actions affects the world.

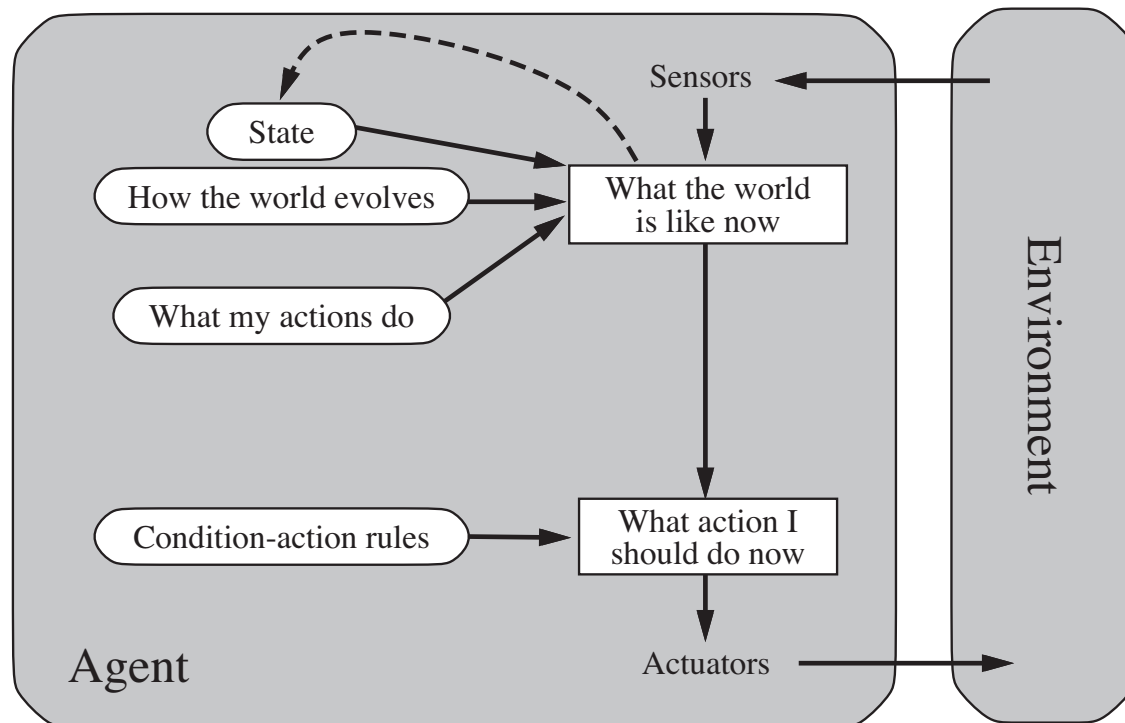

Goal-based agents

- Knowing the current state of the environment is not enough. The agent needs some **goal information**.
- Agent program combines the goal information with the environment model to choose the actions that achieve that goal.
- Consider the future with “What will happen if I do A?”
- Flexible as knowledge supporting the decisions is explicitly represented and can be modified.

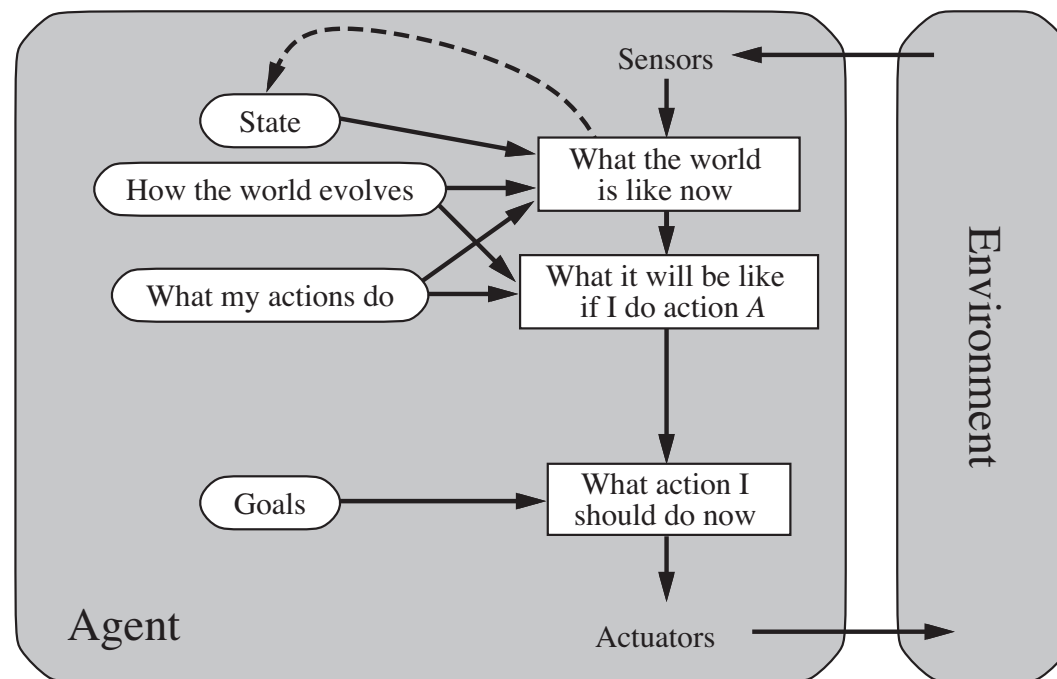

Utility-based agents

- Sometimes achieving the desired goal is not enough. We may look for quicker, safer, cheaper trip to reach a destination.
- Agent happiness should be taken into consideration. We call it **utility**.
- A utility function is the agent's performance measure
- Because of the uncertainty in the world, a utility agent chooses the action that maximizes the expected utility.

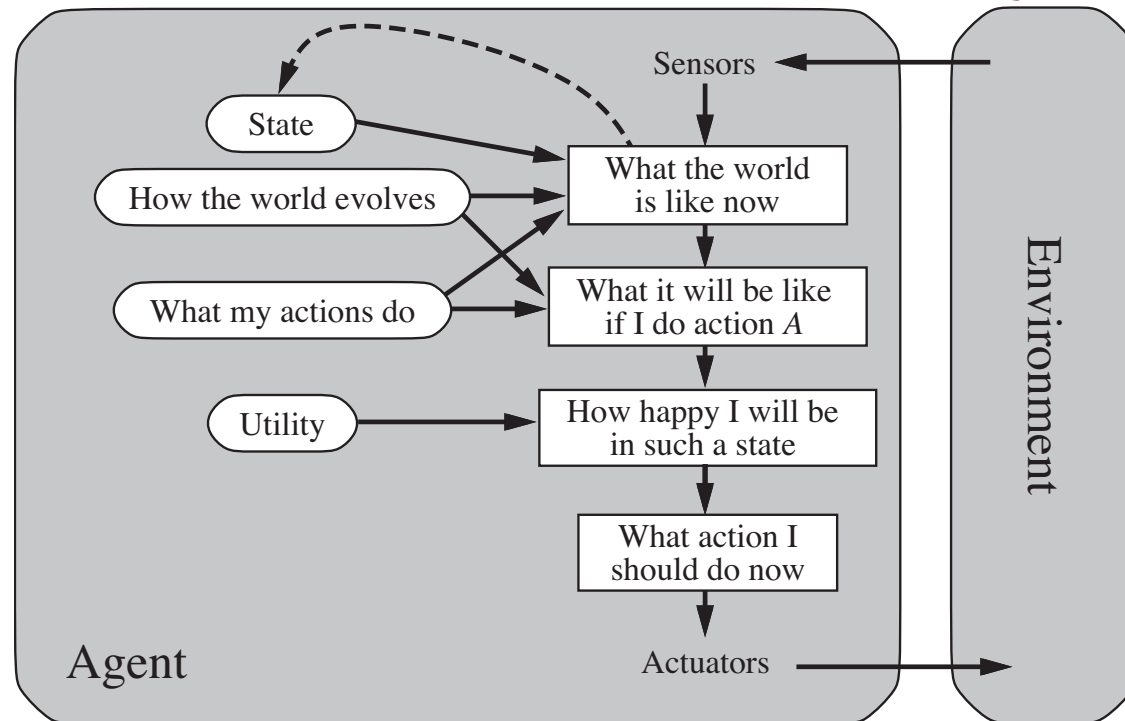

Learning agents

- Programming agents by hand can be very tedious. “Some more expeditious method seem desirable” Alan Turing, 1950.
- Four conceptual components:
 - Learning element: responsible for making improvements
 - Performance element: responsible for selecting external actions. It is what we considered as agent so far.
 - Critic: How well is the agent is doing w.r.t. a fixed performance standard.
 - Problem generator: allows the agent to explore.

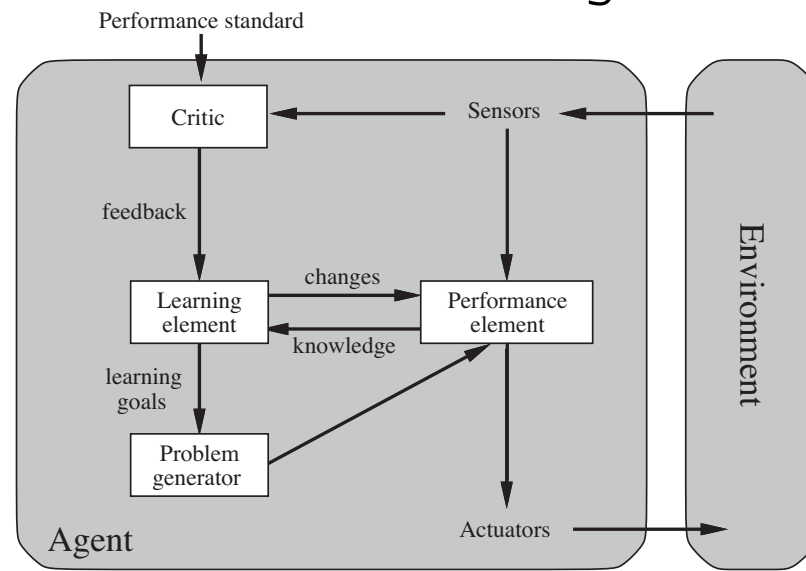

Agent's organization

a) Atomic Representation: Each state of the world is a **black-box** that has no internal structure. E.g., finding a driving route, each state is a city. AI algorithms: search, games, Markov decision processes, hidden Markov models, etc.

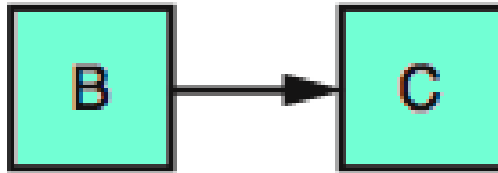

Agent's organization

b) Factored Representation: Each state has some **attribute-value properties**. E.g., GPS location, amount of gas in the tank. AI algorithms: constraint satisfaction, and Bayesian networks.

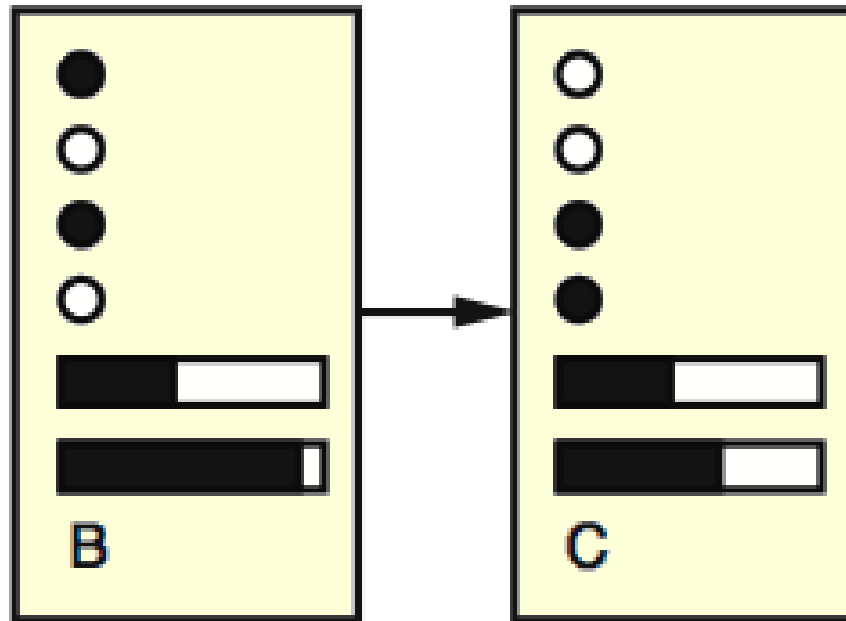

Agent's organization

c) Structured Representation: Relationships between the objects of a state can be explicitly expressed. AI algorithms: first order logic, knowledge-based learning, natural language understanding.

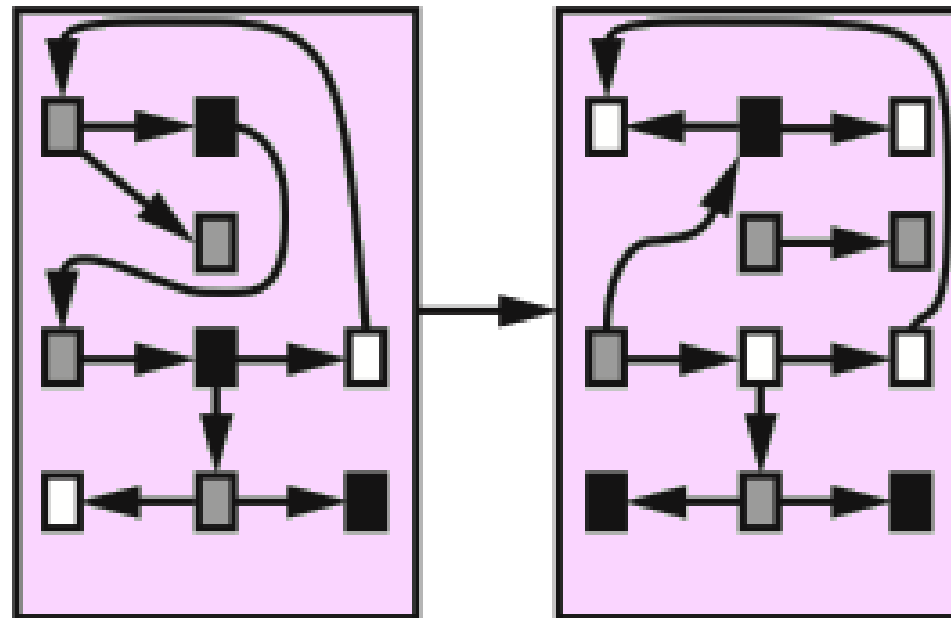

Intelligent agents

- The concept of intelligent agent is central in AI.
- AI aims to design intelligent agents that are useful, reactive, autonomous and even social and pro-active.
- An agent perceives its environment through percept and acts through actuators.
- A performance measure evaluates the behavior of the agent.
- An agent that acts to maximize its expected performance measure is called a rational agent.
- PEAS: A task environment specification that includes Performance measure, Environment, Actuators and Sensors.

Agent = Architecture + Program

Intelligent agents

- Four types of agents: Reflex agents, model-based agents, goal-based agents, and utility-based agents.
- Agents can improve their performance through **learning**.
- This is a high-level present of agent programs.
- States representations: atomic, factored, structured. Increasing expressiveness power.

Intelligent agents

- Four types of agents: Reflex agents, model-based agents, goal-based agents, and utility-based agents.
- Agents can improve their performance through **learning**.
- This is a high-level present of agent programs.
- States representations: atomic, factored, structured. Increasing expressiveness power.

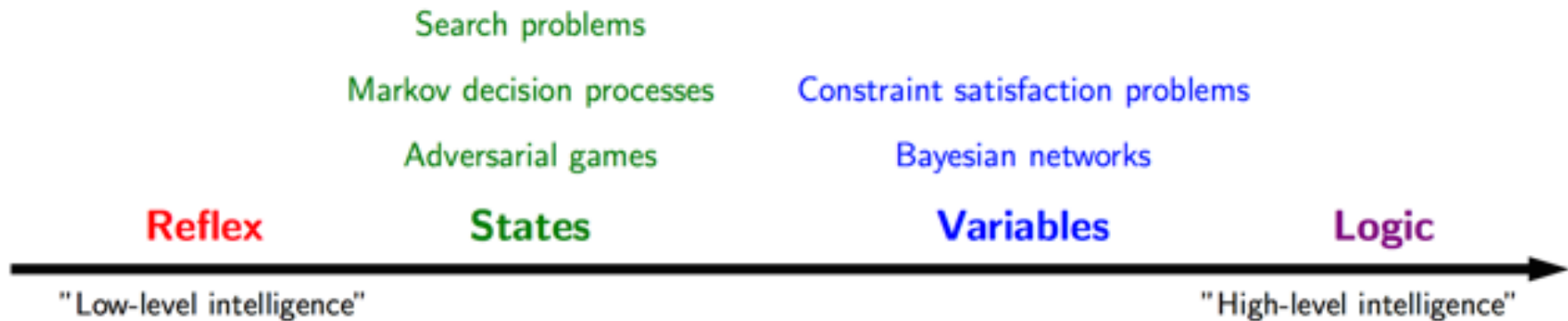

Credit: Courtesy Percy Liang

Credit

- Artificial Intelligence, A Modern Approach. Stuart Russell and Peter Norvig. Third Edition. Pearson Education.

<http://aima.cs.berkeley.edu/>