

Note: these notes were compiled from Dudek and Jenkin, *Computational Principles of Mobile Robotics*.

1 Differential Drive Kinematics

Many mobile robots use a drive mechanism known as differential drive. It consists of 2 drive wheels mounted on a common axis, and each wheel can independently being driven either forward or backward.

While we can vary the velocity of each wheel, for the robot to perform rolling motion, the robot must rotate about a point that lies along their common left and right wheel axis. The point that the robot rotates about is known as the ICC - *Instantaneous Center of Curvature* (see figure 1).

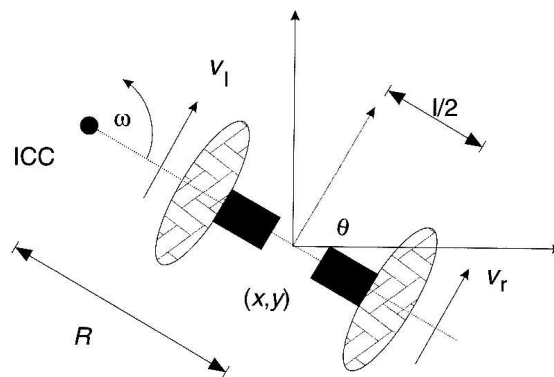

Figure 1: Differential Drive kinematics (from Dudek and Jenkin, *Computational Principles of Mobile Robotics*).

By varying the velocities of the two wheels, we can vary the trajectories that the robot takes. Because the rate of rotation ω about the ICC must be the same for both wheels, we can write the following equations:

$$\omega (R + l/2) = V_r \quad (1)$$

$$\omega (R - l/2) = V_l \quad (2)$$

where l is the distance between the centers of the two wheels, V_r , V_l are the right and left wheel velocities along the ground, and R is the signed distance from the ICC to the midpoint between the wheels. At any instance in time we can solve for R and ω :

$$R = \frac{l}{2} \frac{V_l + V_r}{V_r - V_l}; \quad \omega = \frac{V_r - V_l}{l}; \quad (3)$$

There are three interesting cases with these kinds of drives.

1. If $V_l = V_r$, then we have forward linear motion in a straight line. R becomes infinite, and there is effectively no rotation - ω is zero.
2. If $V_l = -V_r$, then $R = 0$, and we have rotation about the midpoint of the wheel axis - we rotate in place.
3. If $V_l = 0$, then we have rotation about the left wheel. In this case $R = \frac{l}{2}$. Same is true if $V_r = 0$.

Note that a differential drive robot cannot move in the direction along the axis - this is a singularity. Differential drive vehicles are very sensitive to slight changes in velocity in each of the wheels. Small errors in the relative velocities between the wheels can affect the robot trajectory. They are also very sensitive to small variations in the ground plane, and may need extra wheels (castor wheels) for support.

2 Forward Kinematics for Differential Drive Robots

In figure 1, assume the robot is at some position (x, y) , headed in a direction making an angle θ with the X axis. We assume the robot is centered at a point midway along the wheel axle. By manipulating the control parameters V_l, V_r , we can get the robot to move to different positions and orientations. (note: V_l, V_r are wheel velocities along the ground).

Knowing velocities V_l, V_r and using equation 3, we can find the ICC location:

$$ICC = [x - R \sin(\theta), y + R \cos(\theta)] \quad (4)$$

and at time $t + \delta t$ the robot's pose will be:

$$\begin{bmatrix} x' \\ y' \\ \theta' \end{bmatrix} = \begin{bmatrix} \cos(\omega \delta t) & -\sin(\omega \delta t) & 0 \\ \sin(\omega \delta t) & \cos(\omega \delta t) & 0 \\ 0 & 0 & 1 \end{bmatrix} \begin{bmatrix} x - ICC_x \\ y - ICC_y \\ \theta \end{bmatrix} + \begin{bmatrix} ICC_x \\ ICC_y \\ \omega \delta t \end{bmatrix} \quad (5)$$

This equation simply describes the motion of a robot rotating a distance R about its ICC with an angular velocity of ω .

Refer to figure 2. Another way to understand this is that the motion of the robot is equivalent to 1) translating the ICC to the origin of the coordinate system, 2) rotating about the origin by an angular amount $\omega \delta t$, and 3) translating back to the ICC.

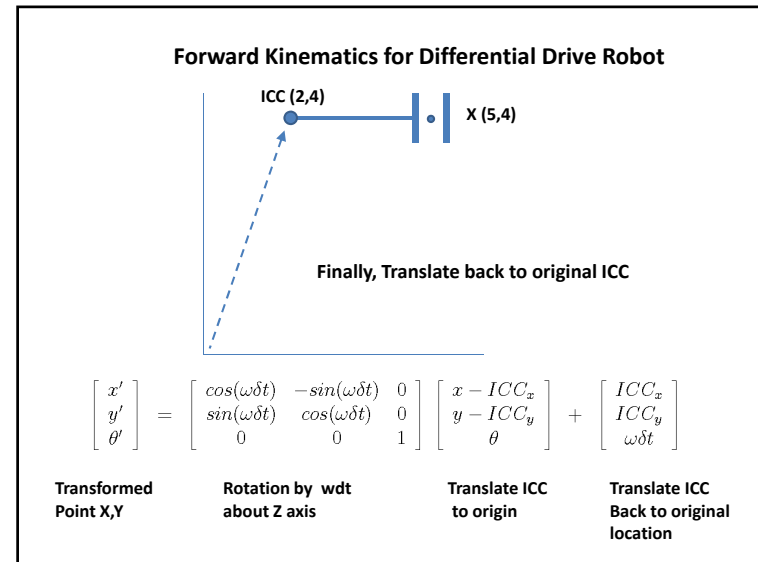
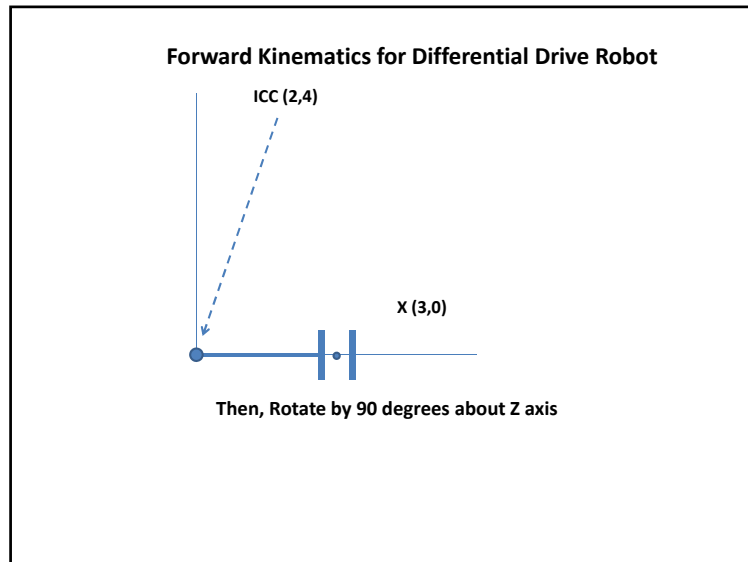
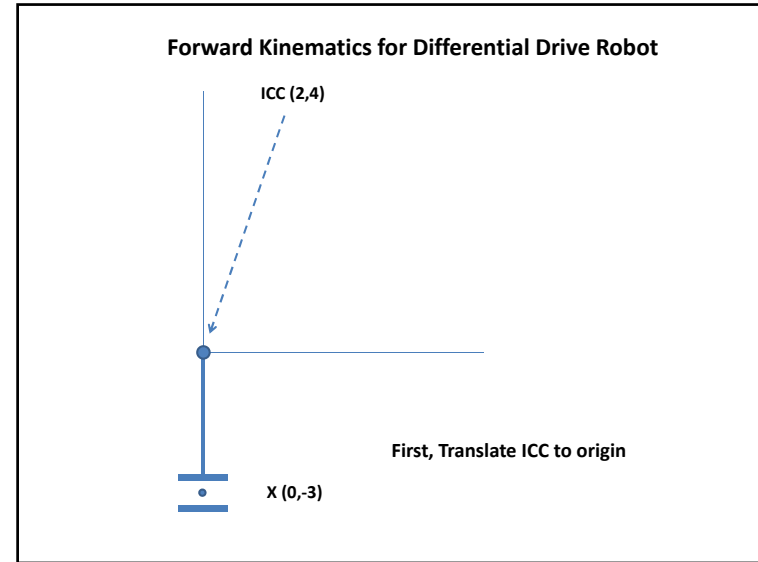
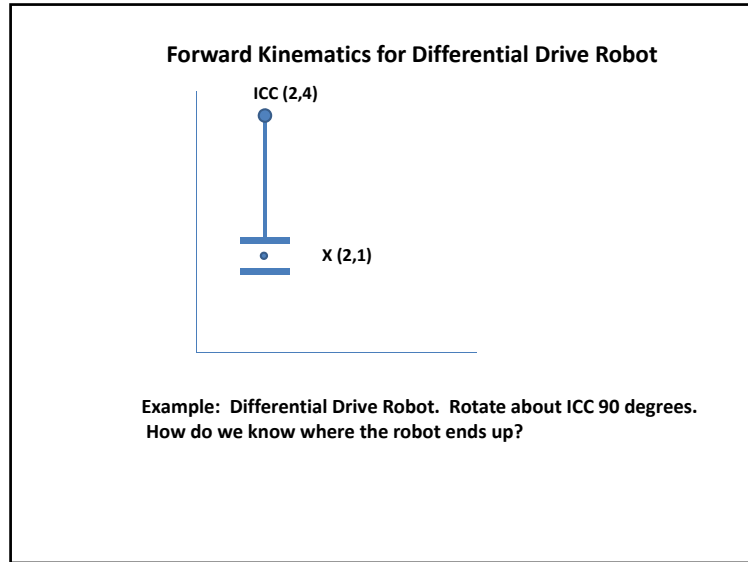

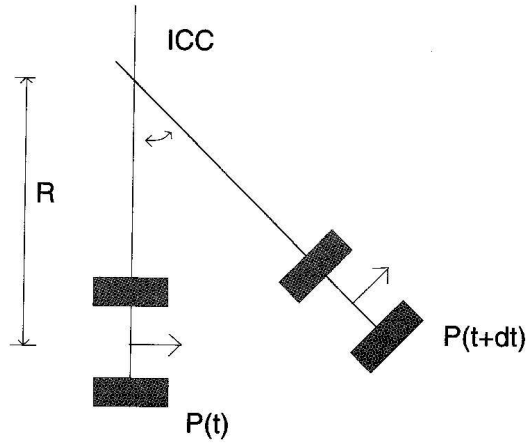

Figure 2: Forward kinematics for differential robot

3 Inverse Kinematics of a Mobile Robot

In general, we can describe the position of a robot capable of moving in a particular direction Θ_t at a given velocity $V(t)$ as:

$$x(t) = \int_0^t V(t) \cos[\theta(t)] dt$$

$$y(t) = \int_0^t V(t) \sin[\theta(t)] dt$$

$$\Theta(t) = \int_0^t \omega(t) dt$$

For the special case of a differential drive robot such as the Create, the equations become:

$$x(t) = \frac{1}{2} \int_0^t [v_r(t) + v_l(t)] \cos[\theta(t)] dt$$

$$y(t) = \frac{1}{2} \int_0^t [v_r(t) + v_l(t)] \sin[\theta(t)] dt$$

$$\Theta(t) = \frac{1}{l} \int_0^t [v_r(t) - v_l(t)] dt$$

A related question is: How can we control the robot to *reach* a given configuration (x, y, θ) - this is known as the inverse kinematics problem.

Unfortunately, a differential drive robot imposes what are called *non-holonomic* constraints on establishing its position. For example, the robot cannot move laterally along its axle. A similar non-holonomic constraint is a car that can only turn its front wheels. It cannot move directly sidewise, as parallel parking a car requires a more complicated set of steering maneuvers. So we cannot simply specify an arbitrary robot pose (x, y, θ) and find the velocities that will get us there.

For the special cases of $v_l = v_r = v$ (robot moving in a straight line) the motion equations become:

$$\begin{bmatrix} x' \\ y' \\ \theta' \end{bmatrix} = \begin{bmatrix} x + v \cos(\theta)\delta t \\ y + v \sin(\theta)\delta t \\ \theta \end{bmatrix} \quad (6)$$

If $v_r = -v_l = v$, then the robot rotates in place and the equations become:

$$\begin{bmatrix} x' \\ y' \\ \theta' \end{bmatrix} = \begin{bmatrix} x \\ y \\ \theta + 2v\delta t/l \end{bmatrix} \quad (7)$$

This motivates a strategy of moving the robot in a straight line, then rotating for a turn in place, and then moving straight again as a navigation strategy for differential drive robots.

4 Mapping Angular Wheel Velocity to Linear Velocity

The left and right wheel velocities used above, V_l, V_r are linear velocities. We actually control the wheels by specifying an angular velocity V_{wheel} for a wheel specified in radians per second. Given V_{wheel} , we need to find out what the resulting linear velocity for that wheel's movement is.

We will use as an example the Khepera robot which is a small robot, similar to the iRobot Create, that uses differential drive. We define the following terms: r_{wheel} : wheel radius. D_{robot} : length of the differential drive wheel axle. V_{wheel} : magnitude of wheel velocity measured in radians/sec.

In this example, let's assume that the wheels are turning in the opposite direction at the same velocity (the robot is turning in place). If we want the robot base to rotate by ϕ degrees, we need to find an equation for the amount of time t we need to run the wheel motor at velocity V_{wheel} to turn the robot an angle of ϕ degrees. The wheel turns a linear distance of $r_{wheel} \cdot \theta$ along its arc where θ is simply $V_{wheel} \cdot t$.

The wheel will travel a distance equal to $r\theta$ along its arc (see figure 3). If we assume a wheel velocity of $V_{wheel} = 10 \text{ radians/sec}$, then the wheel will travel $10 \cdot 8 = 80 \text{ mm}$ in 1 sec, which is also equivalent to .08mm in 1 msec.

Given a time t , the wheel will turn:

$$Dist_{wheel} = r_{wheel} * V_{wheel} * t$$

To determine the time to turn the robot a specified angle in place, we note that the entire circumference C of the robot when it turns 360° is πD_{robot} . We can turn an angle of ϕ in time t using the equation:

$$\frac{Dist_{wheel}}{C} = \frac{\phi}{2\pi} \quad (\phi \text{ measured in radians})$$

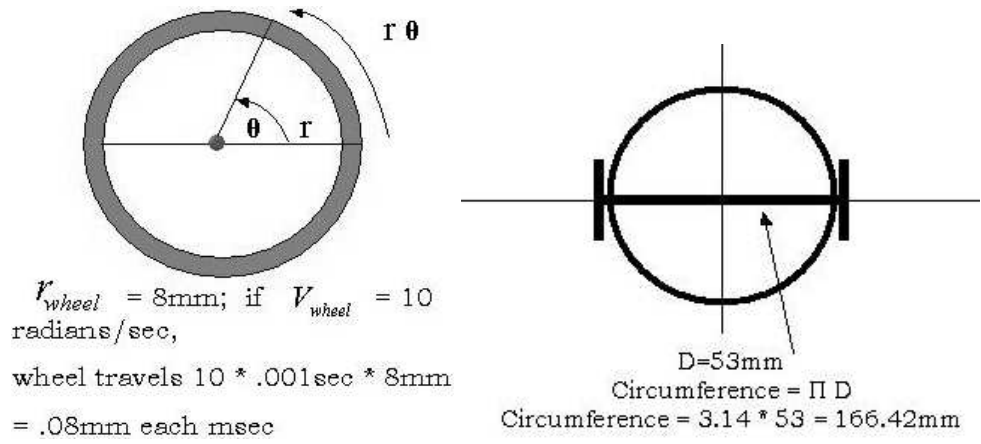

Figure 3: Left: Khepera wheel dimensions. Right: Khepera robot dimensions

$$\frac{V_{wheel} * r_{wheel} * t}{C} = \frac{\phi}{2\pi} \quad (\phi \text{ measured in radians})$$

$$t = \frac{\phi C}{2\pi V_{wheel} * r_{wheel}}$$

Example: suppose you want to turn a Khepera robot 90° . For the Khepera, r_{wheel} is 8mm, D_{robot} is 53mm, and we can set the speed of the wheel to 10 radians/sec:

So to turn 90° ($\frac{\pi}{2}$ radians):

$$T = \frac{\phi C}{2\pi V_{wheel} * r_{wheel}} = \frac{\frac{\pi}{2} 166.42}{2\pi * 8 * 10} = .52 \text{ secs}$$

So your control parameter t given a specified velocity can be found.