

Product Brief

# LBT400DV – VoIP Cable Modem Telephony Reference Design

The Texas Instruments (TI) LBT400DV is the first-generation VoIP Cable Modem Telephony Reference Design that integrates TI's Cable Broadband Communications (formerly Libit) and Telygy technologies. This reference design supports both data communications and VoIP telephony. The LBT400DV combines Texas Instruments powerful cable modem and DSP technology with Telygy Networks', a Texas Instruments company, Golden Gateway® Voice-over-Internet Protocol embedded communications software. The integrated Voice-over-IP solution contains circuitry for connecting four telephones and providing

many of the enhanced features of the circuit-switched network through the cable television infrastructure.

The LBT400DV was developed to meet the stringent CableLabs certification criteria (previously known as DOCSIS or Data Over Cable Service Interface Specification). All of the components necessary to build a VoIP-enabled cable modem – including TI-CBC's LBT4030 and LBT4230 DOCSIS cable modem chipset, a RISC processor, the TI TMS320C5402 DSP, codecs and subscriber line interfaces – have been integrated into the reference design, shorten-

ing the development cycle time for cable modem manufacturers.

This low-cost, high-performance, DOCSIS solution for Voice-over-IP includes a highly-optimized DOCSIS software driver and application. The solution includes: baseline privacy and SNMP for remote management; complete DSP software – echo canceller, codecs, tone detectors, packet formatter (RTP playout buffer), caller ID and conferencing; and complete MGCP telephony signaling software.

The LBT400DV further supports 16 independent and configurable service IDs (SIDs) for DOCSIS Quality of Service (QoS).

DOCSIS software is available in well-documented source code for rapid development, and the whole system is provided as a reference design for VoIP cable equipment vendors.

The LBT400DV is the first step in TI's aggressive roadmap for providing the best and most cost-effective solutions for VoIP over cable.

## Key Benefits

- This reference design can be used as an evaluation platform for hardware and software development by cable modem developers and manufacturers
- TI's cable modem technology has been tested for interoperability at CableLabs and has successfully interoperated with all major cable modem and termination system vendors
- Complete low-cost, high-performance DOCSIS and PacketCable solution enables shortest product development time
- Highly-optimized DOCSIS software driver and API shortens time-to-market
- Very fast channel acquisition minimizes connection time
- Complete DSP software: echo canceller, codecs, tone detectors, packet formatter (RTP playout buffer), caller ID, conferencing
- Complete MGCP telephony signaling software
- Supports 16 independent and configurable service IDs (SIDs) for DOCSIS QoS which allows the highest number of premise equipment devices to be connected to a single cable modem



## Features

- Complete low-cost, high-performance, DOCSIS and Packet-Cable solution
- Subscriber line interface card (SLIC) containing four RJ-11 telephone interfaces for VoIP
- Fully tested and shown as interoperable at CableLabs
- Highly-optimized DOCSIS software driver and API
- Designed to work with industry-standard real-time operating systems
- Complete DOCSIS code supplied
- Low-cost, high-quality RF design
- Complete documentation
- External interfaces: USB, RJ-45 (Ethernet), RJ-11 (telephone)
- Compliant with ITU-T J.83 Annex B PHY and ITU-T J.112 Annex B MAC specifications
- Supports immediate data mode and concatenation for enhanced upstream performance and QoS
- Complete DSP software: echo canceller, codecs, tone detectors, packet formatter (RTP playout buffer), caller ID and conferencing
- Complete MGCP telephony signaling software
- Very fast channel acquisition
- Supports 16 independent and configurable service IDs (SIDs) for DOCSIS QoS
- Supports up to 16 customer premise equipment (CPE) devices
- Supports SNMP (MIB-II and DOCSIS MIB enhancements) for remote management
- Includes schematics, Gerber files, bill of materials (BOM) and software code
- Major components: TI's LBT4030 CM transceiver, TI's LBT4230 MAC chip, TI's TMS320C5402 DSP, Toshiba's VA8XMA tuner, codecs, and Motorola's MPC850 CPU

## System Architecture

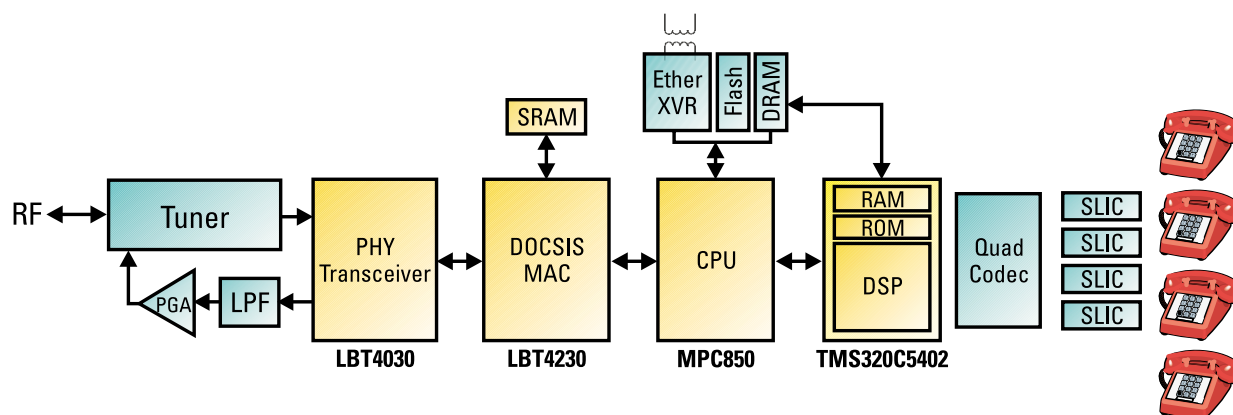

For more information, please contact the nearest TI sales office or visit our web site:  
[www.ti.com/sc/cablemodem](http://www.ti.com/sc/cablemodem)