

# Sprite Graphics

Prof. Stephen A. Edwards  
sedwards@cs.columbia.edu

Columbia University  
Spring 2008

Sprite Graphics - p.

# Sprite Graphics: Pac-Man



Sprite Graphics - p.

# Sprite Graphics: Super Mario Bros



Sprite Graphics - p.

# Sprite Graphics: Excitebike



Sprite Graphics - p.

# Nintendo NES/Famicom

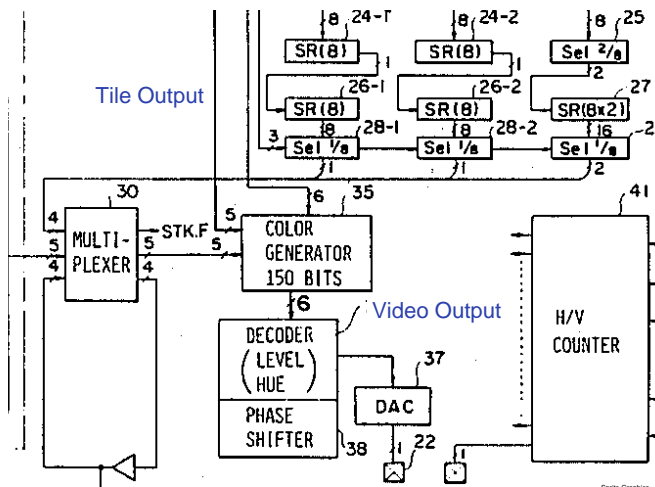
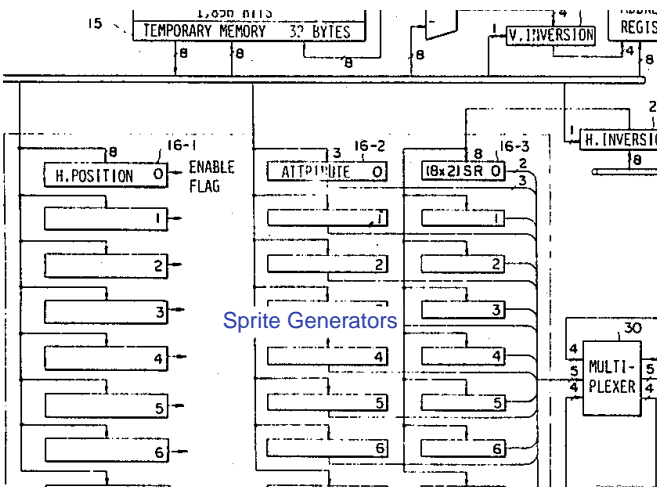
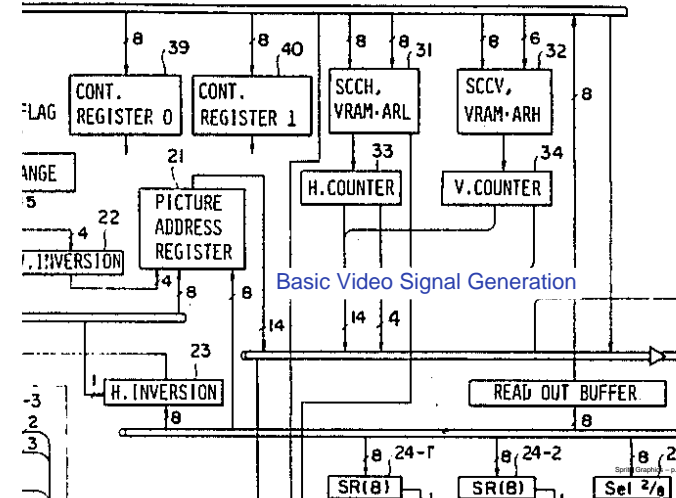
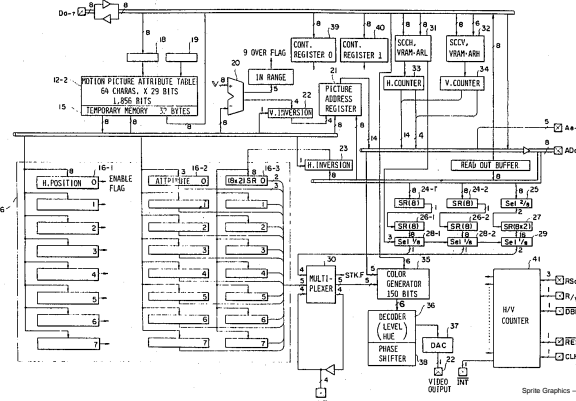

# Basic Operation

- For each line,
- Fetch color palette
  - Fetch tiles
  - Fetch tile bitmaps
  - Read sprite location data for 64 sprites
  - Save and prioritize up to 8 visible sprites

## Simplified Memory Map

Pattern Table: bitmaps for tiles & sprites
Name Table: Tile numbers
Attribute Table: Extra tile color information
Sprite Palette: 16 colors
Tile Palette: 16 colors
Sprite Information

Sprite Graphics - p. 1

## Sprite Information

7							0	
Y coordinate								
Tile (bitmap) number								
Vertical Flip	Horizontal Flip	Priority	0	0	0	b3	b2	b1
color bits								
X coordinate								

Tiles are  $2 \times 8$  bytes each. First 8 are bitmaps of LSB color value, next 8 are next color bit.

Sprite Graphics - p. 1

## References

Steven Collins. Computer Graphics during the 8-bit Computer Game Era. Siggraph Newsletter, 32(2) May 1998.

NES Development <http://nesdev.parodius.com>

NES Palette Generator

[http://nesdev.parodius.com/kevin\\_palette.txt](http://nesdev.parodius.com/kevin_palette.txt)

Nintendo Entertainment System Documentation v. 0.40.

[http://db.gamefaqs.com/console/nes/file/nes\\_tech.](http://db.gamefaqs.com/console/nes/file/nes_tech.)

Ueda et al. TV Game System Having Reduced Memory Needs. United States Patent #4,824,106. April 25, 1989.

Sprite Graphics - p. 1