



Hardware-Software Interfaces

CSEE W4840

Prof. Stephen A. Edwards

Columbia University

Spring 2006

Basic Processor Architecture

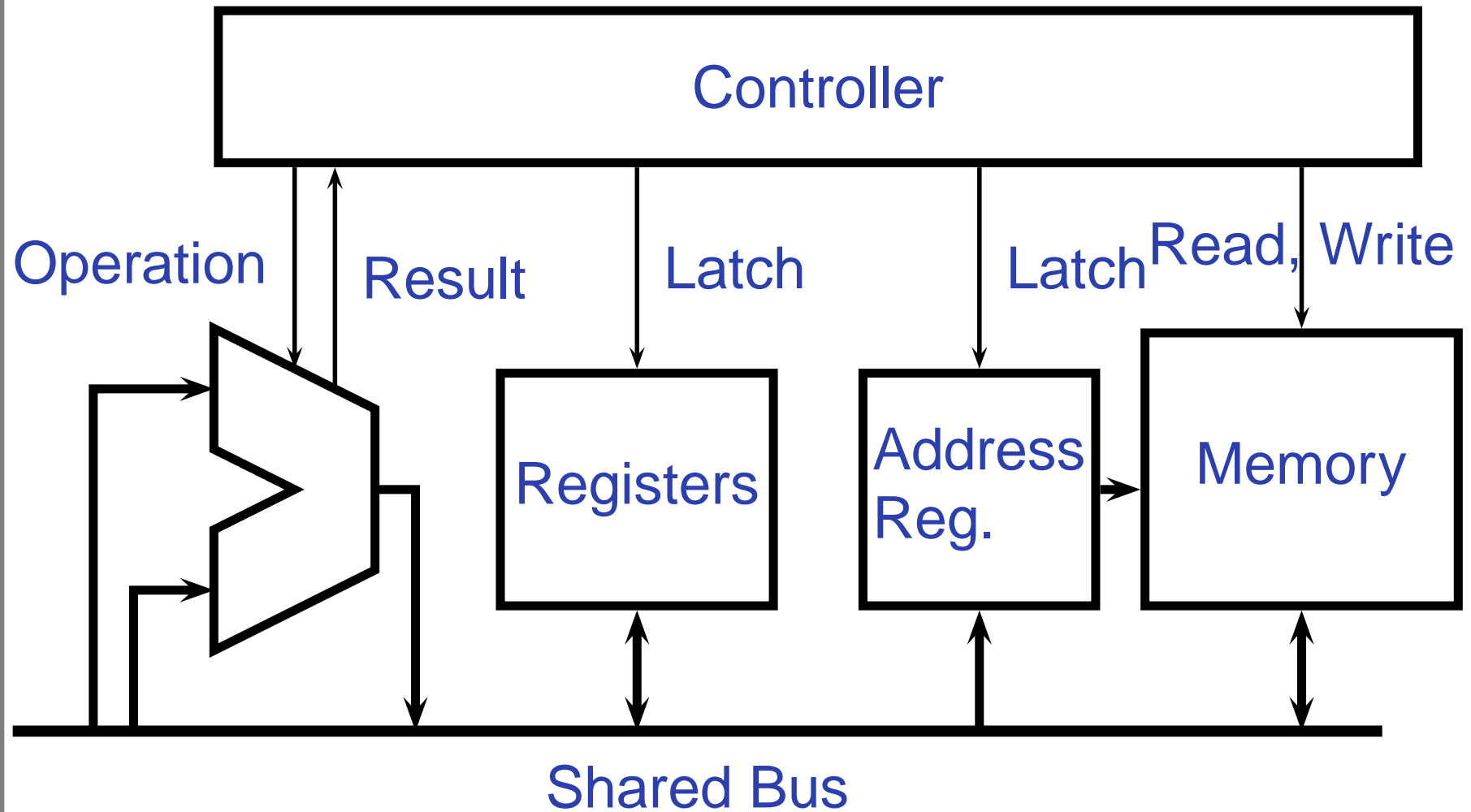

Typical Processor System

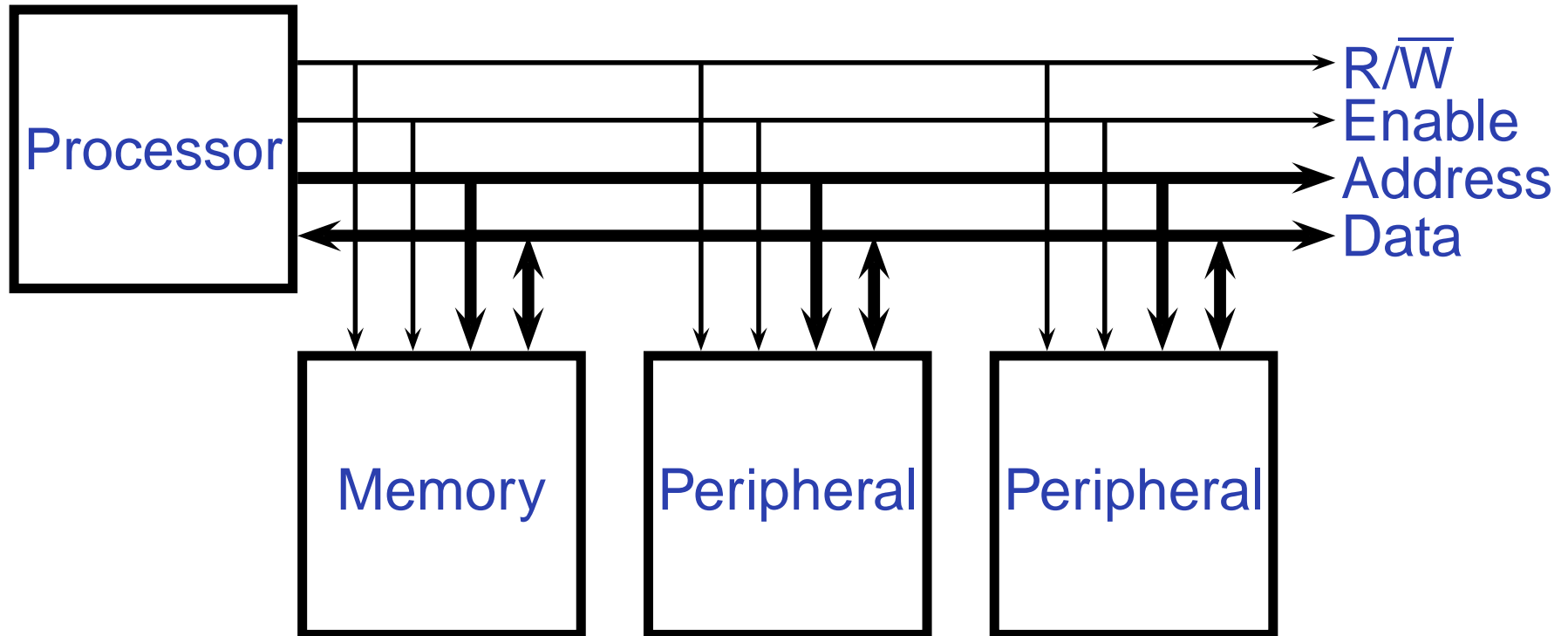

Simple Bus Timing

Read Cycle

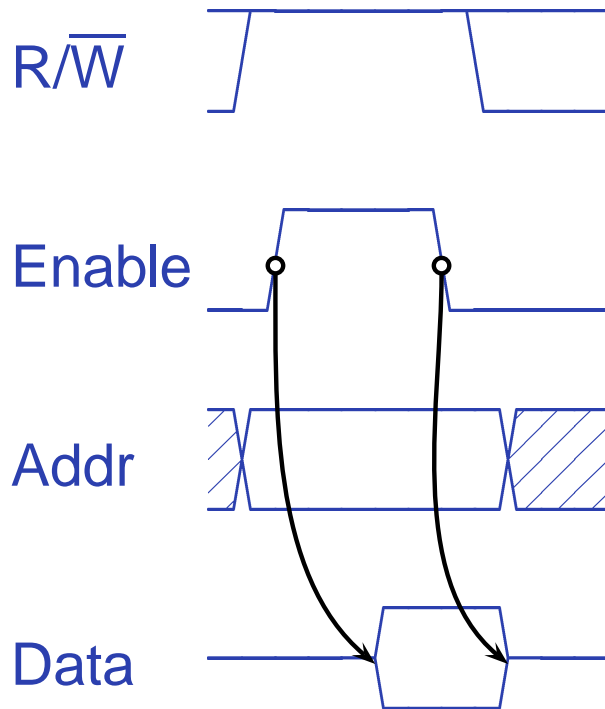

Write Cycle

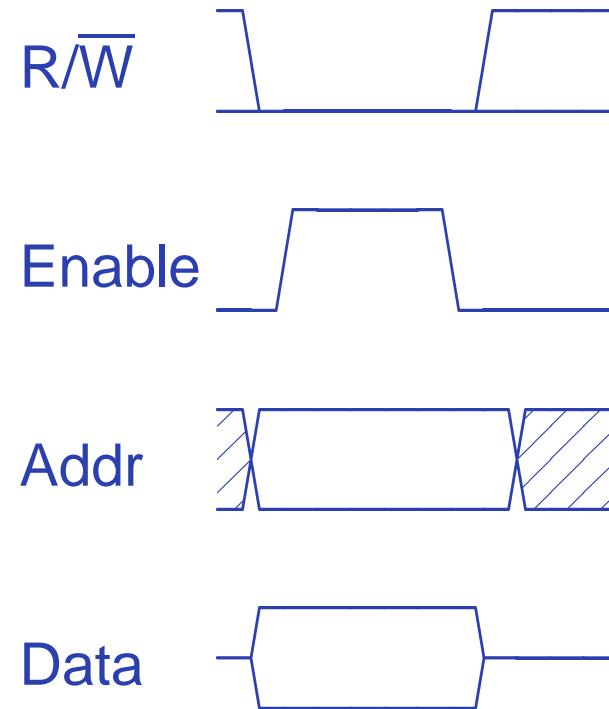

Strobe vs. Handshake

Strobe

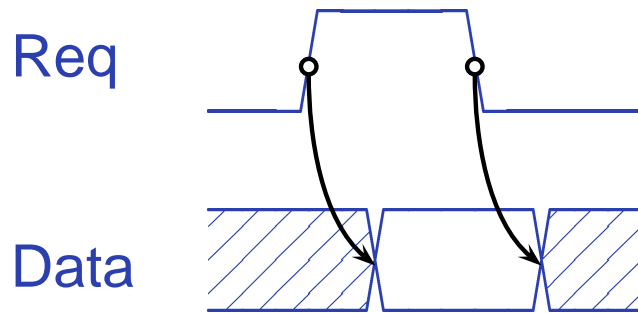

Handshake

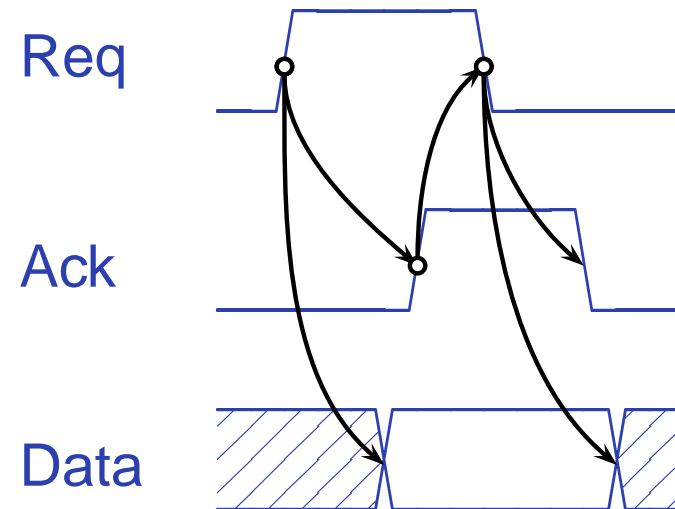

1982: The IBM PC

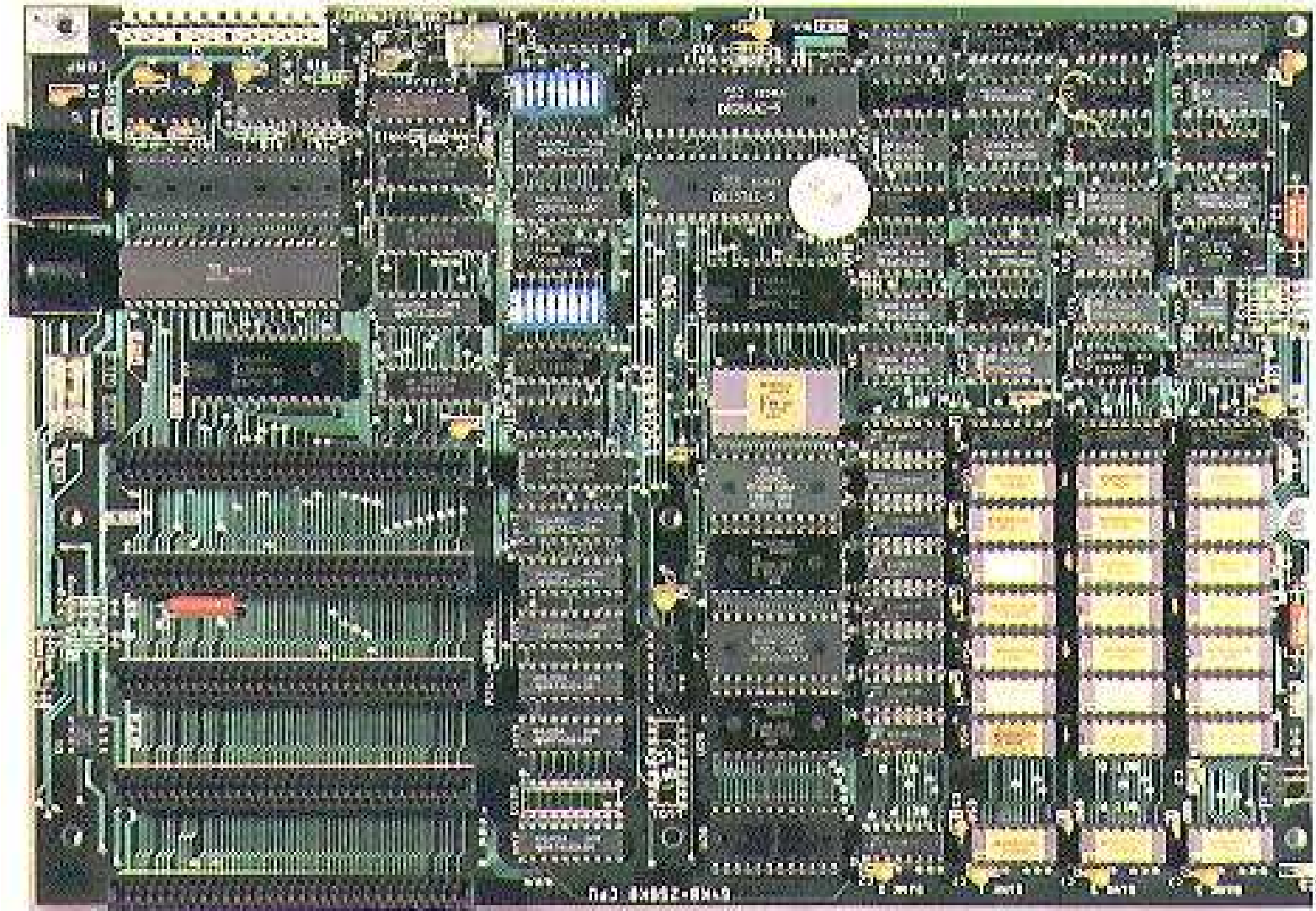

The ISA Bus: Memory Read

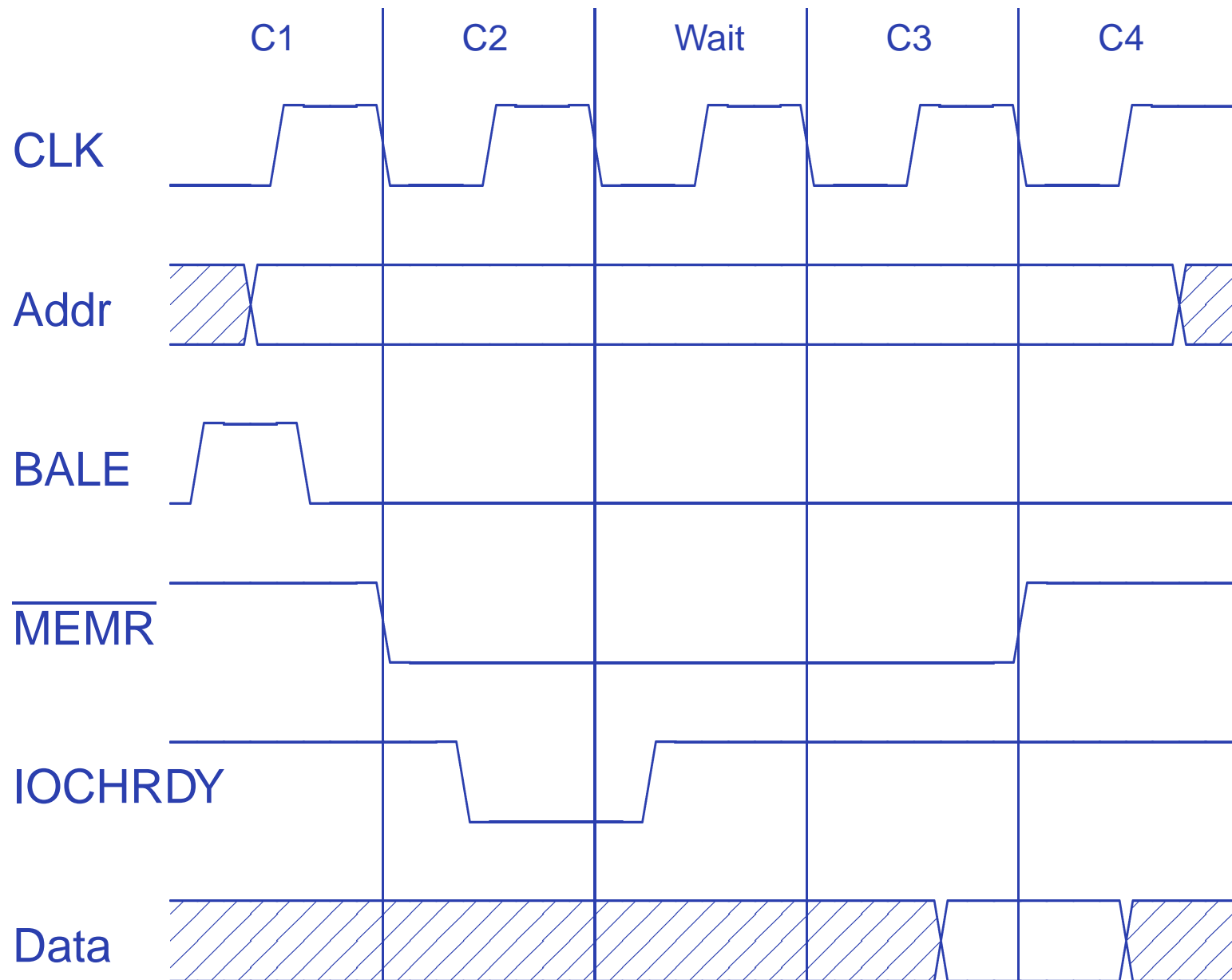

The ISA Bus: Memory Write

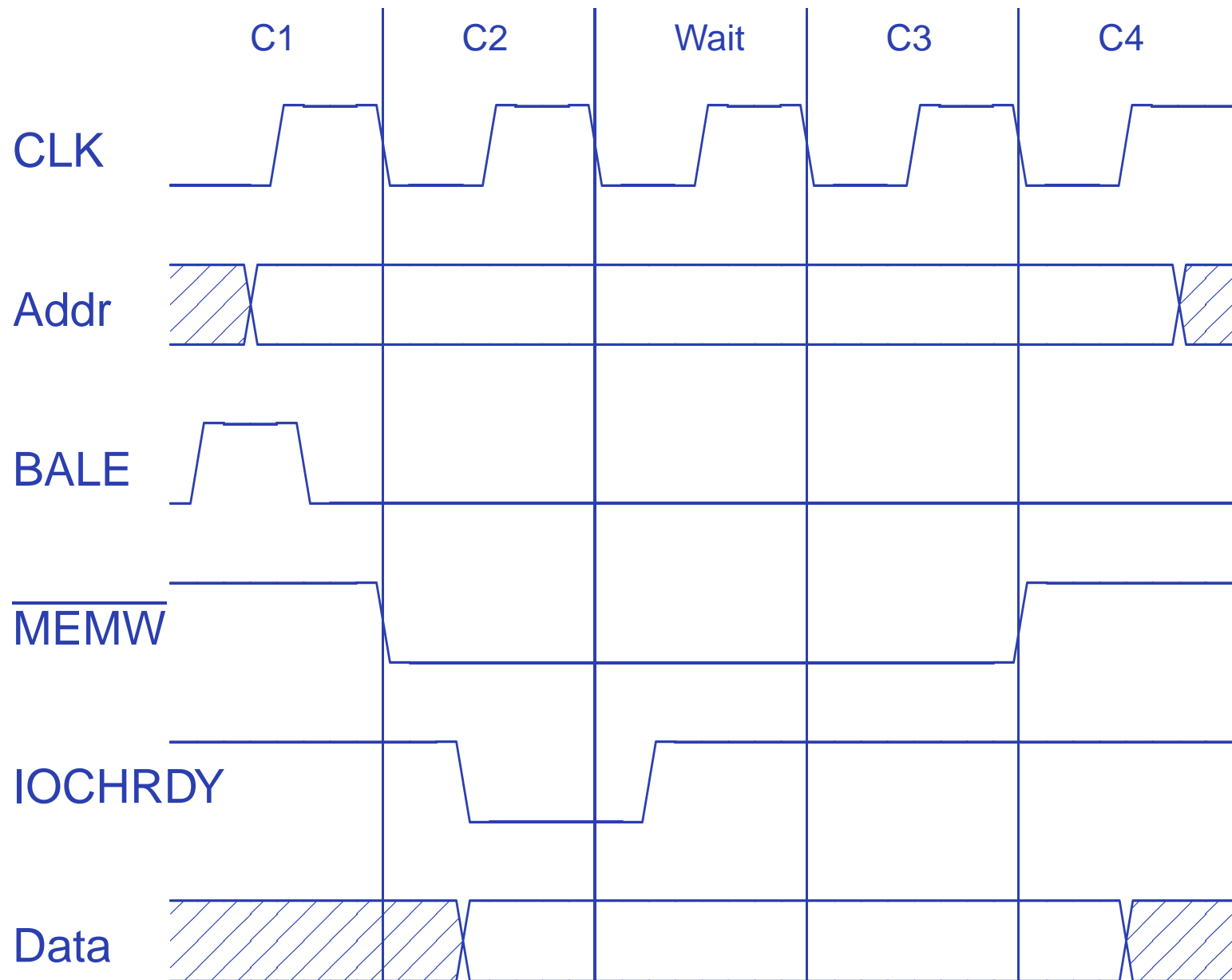

The PC/104 Form Factor: ISA Lives

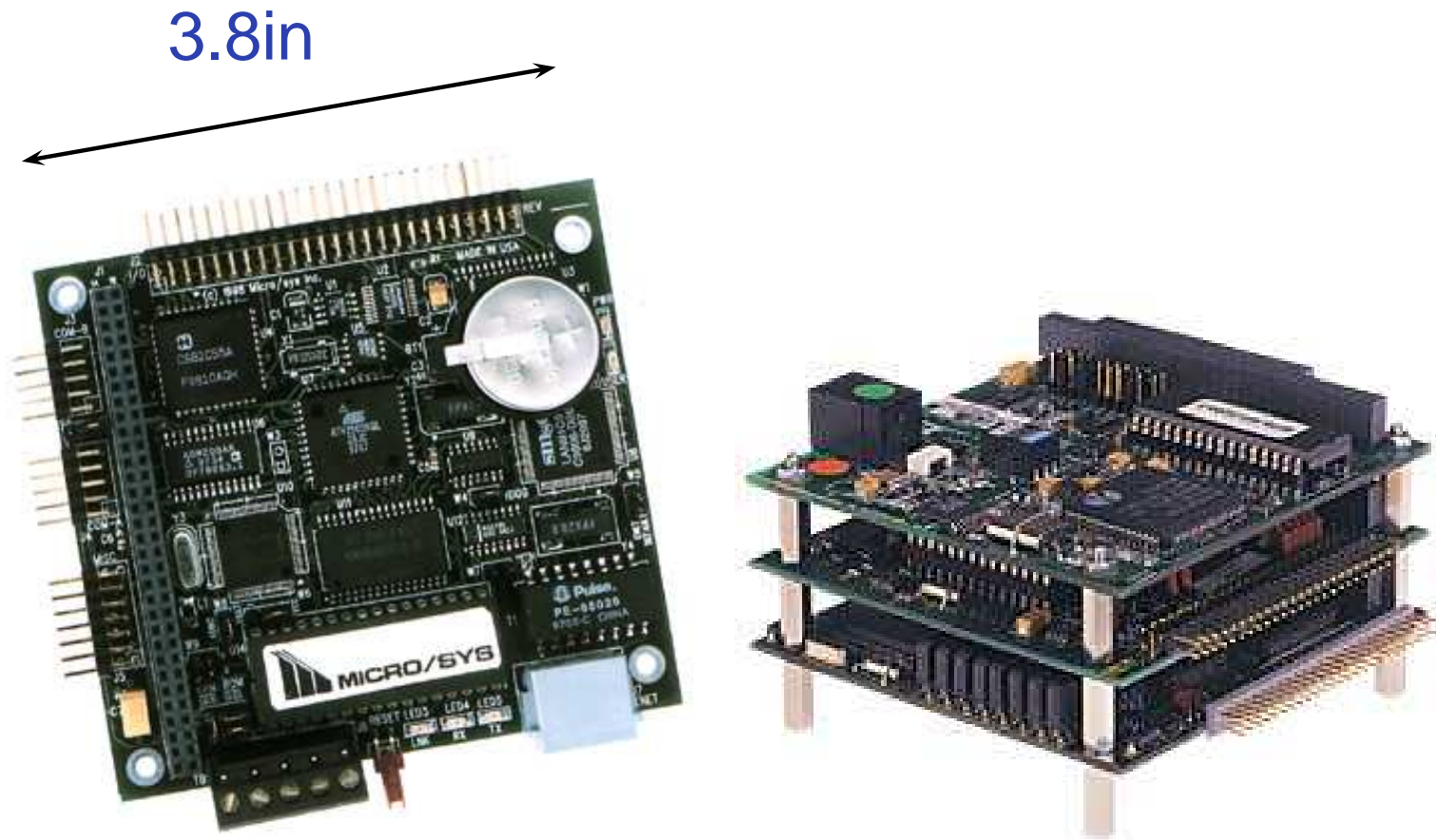

Embedded System Legos. Stack 'em and go.

Memory-Mapped I/O

- To a processor, everything is memory.
- Peripherals appear as magical memory locations.
- Status registers: when read, report state of peripheral
- Control registers: when written, change state of peripheral

Typical Peripheral: PC Parallel Port

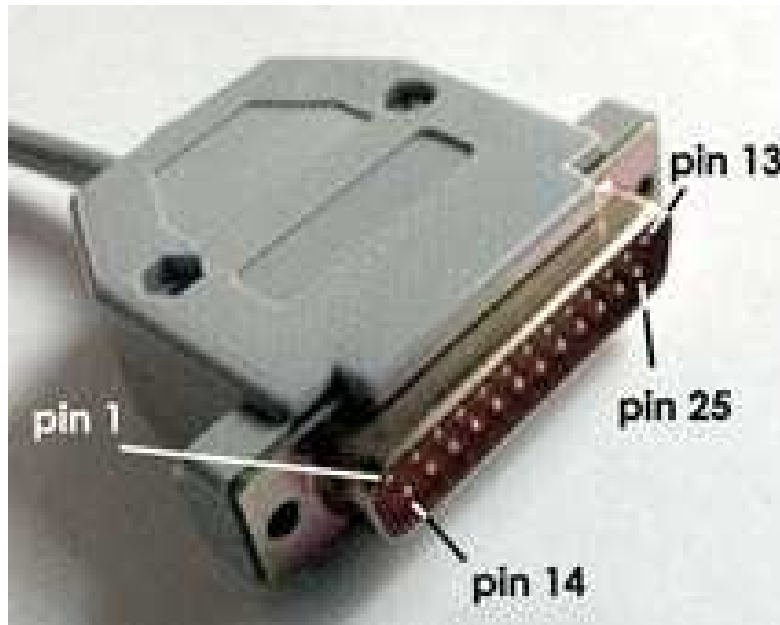

Centronics Handshake

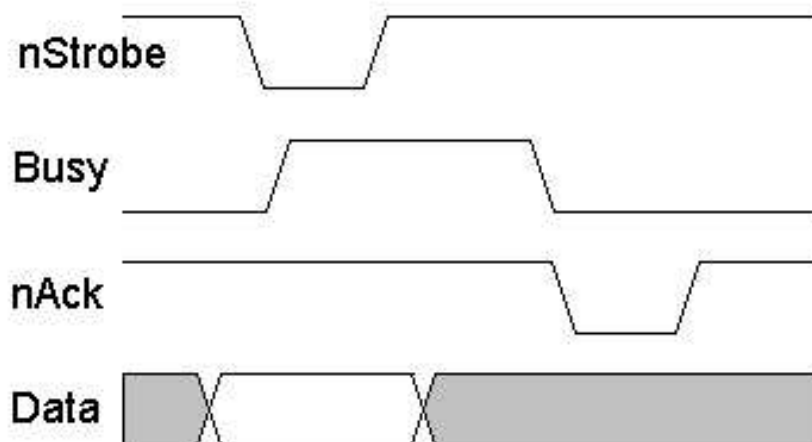

At Standard TTL Levels

	Signal Name	Adapter Pin Number	
	-Strobe	1	
E	+Data Bit 0	2	P
X	+Data Bit 1	3	A
T	+Data Bit 2	4	R
E	+Data Bit 3	5	A
R	+Data Bit 4	6	L
N	+Data Bit 5	7	L
A	+Data Bit 6	8	E
L	+Data Bit 7	9	L
	-Acknowledge	10	
D	+Busy	11	A
E	+Paper End	12	D
V	+Select	13	A
I	-Auto Feed	14	P
C	-Error	15	T
E	-Initialize	16	E
	-Select Input	17	R
	Ground	18-25	

Parallel Port Registers

D7	D6	D5	D4	D3	D2	D1	D0	0x378
$\overline{\text{Busy}}$	Ack	Paper	Sel	Err				0x379
				$\overline{\text{Sel}}$	Init	$\overline{\text{Auto}}$	$\overline{\text{Strobe}}$	0x37A

1. Write Data
2. Assert Strobe
3. Wait for Busy to clear
4. Wait for Acknowledge

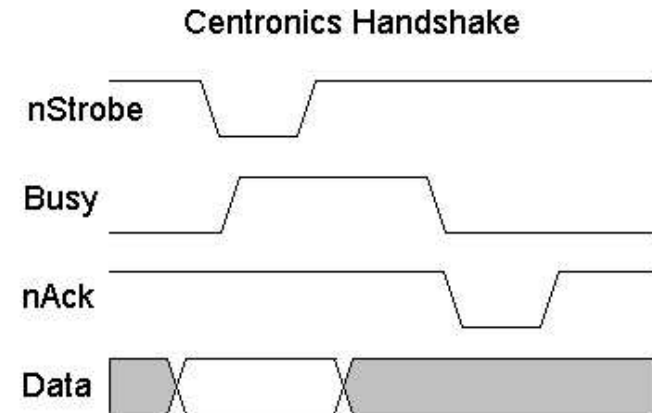

A Parallel Port Driver

```
#define DATA      0x378
#define STATUS    0x379
#define CONTROL   0x37A

#define NBSY      0x80
#define NACK      0x40
#define OUT       0x20
#define SEL       0x10
#define NERR      0x08
#define STROBE    0x01

#define INVERT    (NBSY | NACK |          SEL | NERR)
#define MASK      (NBSY | NACK | OUT | SEL | NERR)
#define NOT_READY(x) ((inb(x)^INVERT)&MASK)

void write_single_character(char c) {
    while (NOT_READY(STATUS)) ;
    outb(DATA, c);
    outb(CONTROL, control | STROBE); /* Assert STROBE */
    outb(CONTROL, control ); /* Clear STROBE */
}
```

Interrupts and Polling

Two ways to get data from a peripheral:

- Polling: “Are we there yet?”
- Interrupts: Ringing Telephone

Interrupts

Basic idea:

1. Peripheral asserts a processor's interrupt input
2. Processor temporarily transfers control to interrupt service routine
3. ISR gathers data from peripheral and acknowledges interrupt
4. ISR returns control to previously-executing program

Many Different Interrupts

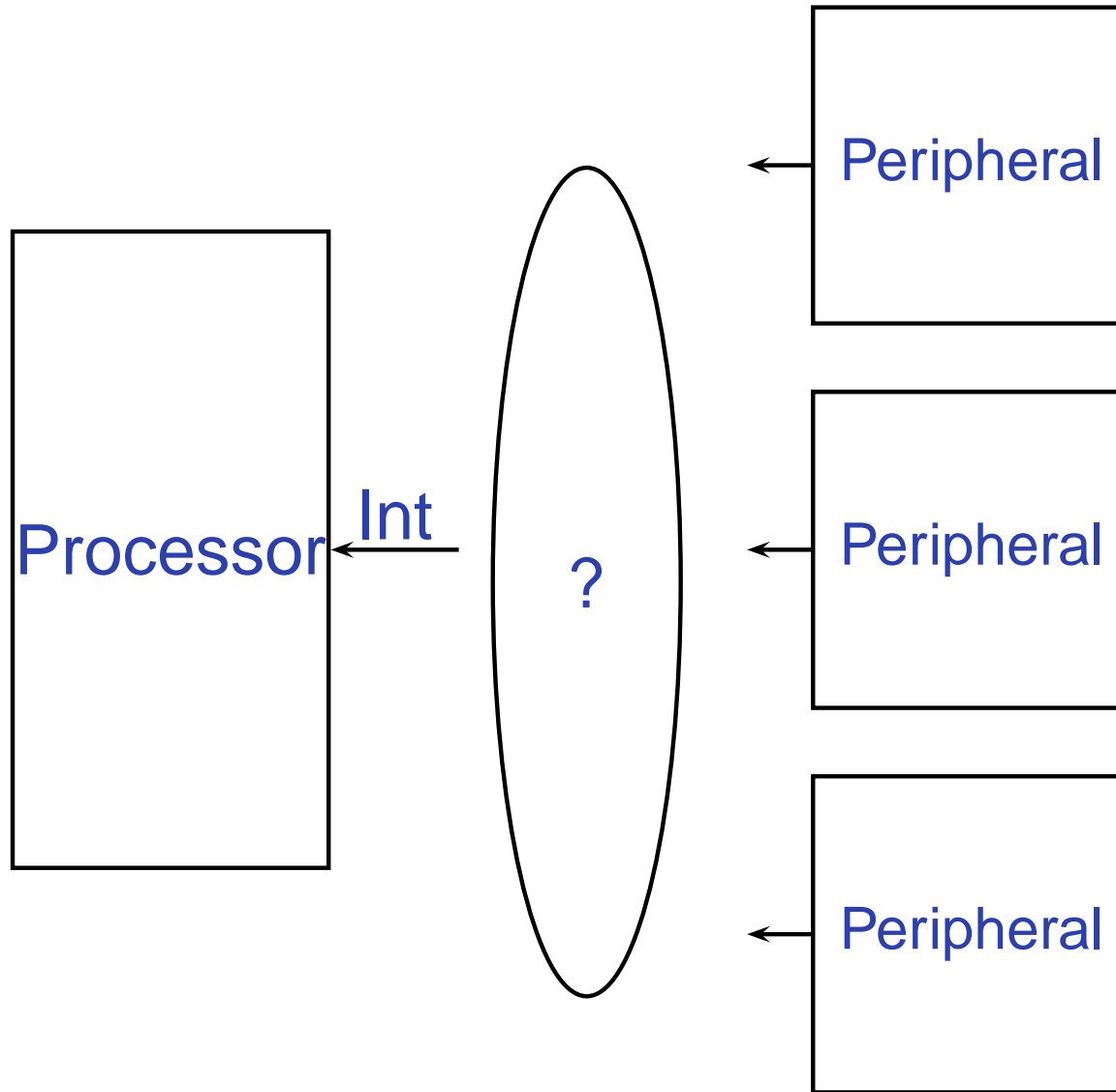

What's a processor to do?

Interrupt Polling

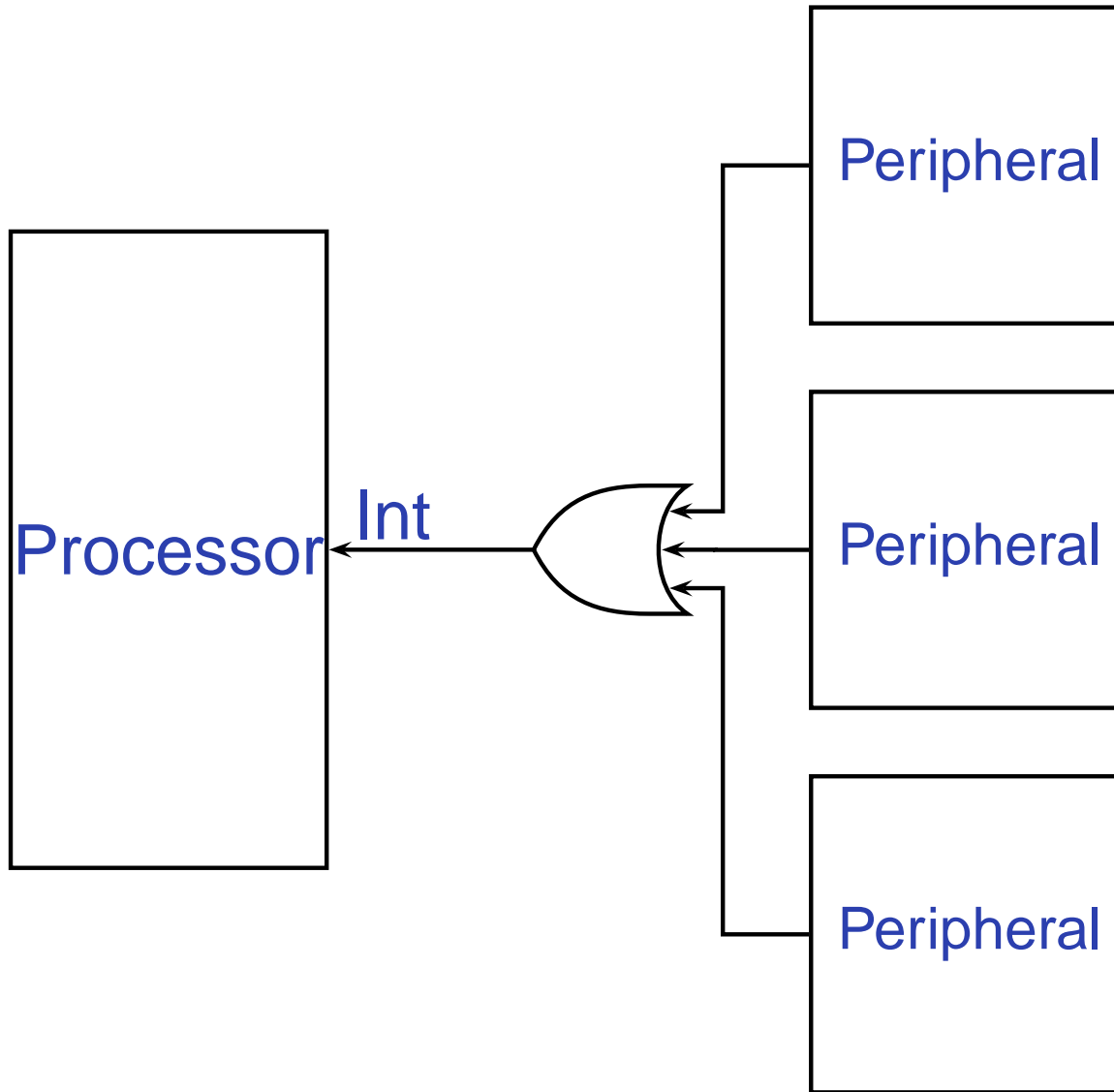

Processor receives interrupt
ISR polls all potential interrupt sources

Intel 8259 PIC

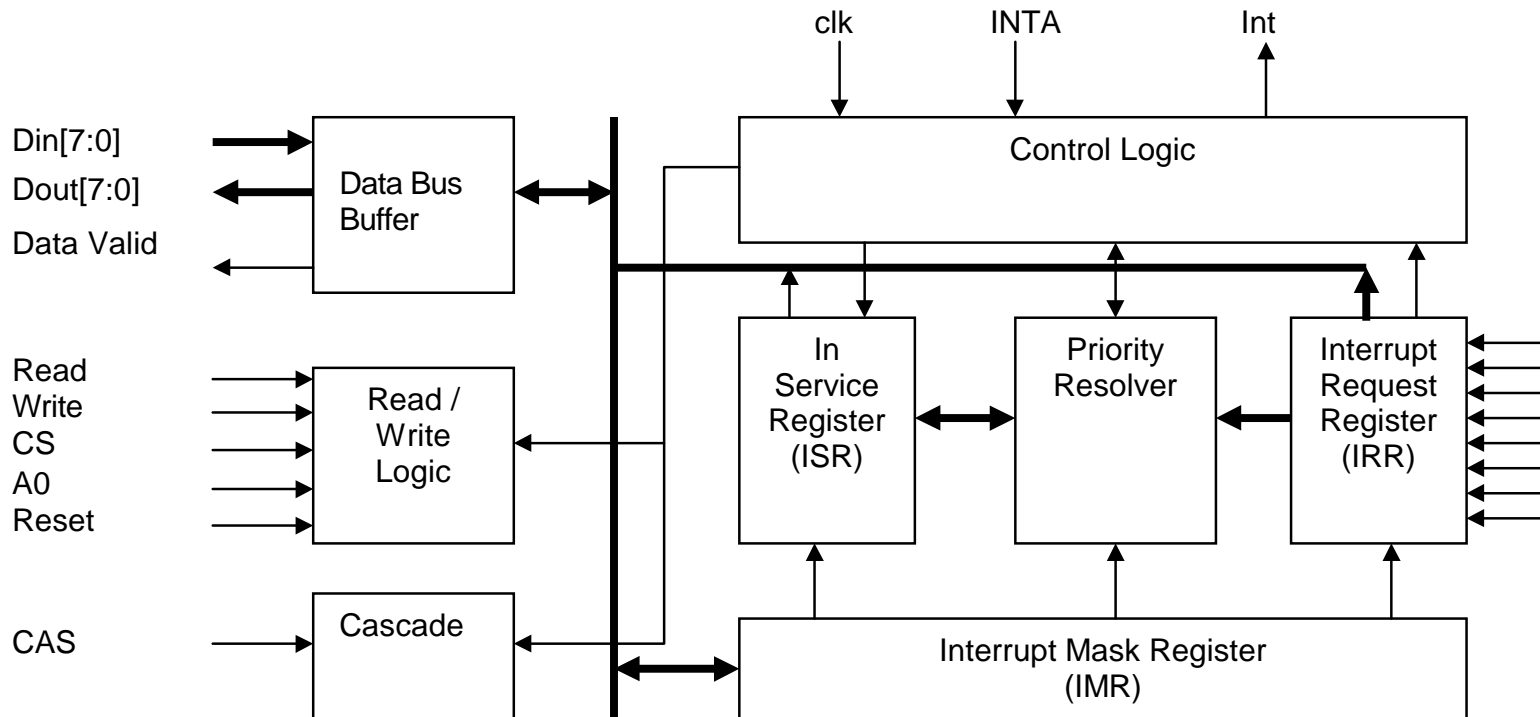

Prioritizes incoming requests & notifies processor
ISR reads 8-bit interrupt vector number of winner
IBM PC/AT: two 8259s; became standard